

PARANORMA

Secret Origin of Darwin's Occult Doctrine

The Beatles' Subliminal Messages to Manson

Does Terrorism Aid U.S. Expansion?

Apollo Hoax Found in NASA Footage!

David Icke: Master of the Reptilian Mythos

40 Years and Finally, Who Shot JFK!



0 74470 84979 7

P

"The potential for the
distrastous rise of
misplaced power exists
and will persist."

Dwight D. Eisenhower,
1961

PARANOIA

Fall 2003
Vol 10 No 2 Issue 33

SUBSCRIBE

We publish 3x per
year (Apr, Aug,
Dec). Get 3 issues
(1-yr) for \$18
(Canada:\$24,
International:\$36,
Money Order US
Funds)

SUBMISSIONS

We welcome
research articles on
disk, 4-8 pgs, single
spaced, with
sources.
Contributions cannot
be returned or paid

DISCLAIMER

All statements
published are not
necessarily held or
promoted by
Paranoia Publishing

CO-PUBLISHERS

Joan d'Arc
Al Hidell

CO-EDITORS

Al Hidell
Joan d'Arc

DESIGN

Al Hidell

PARANOIA
PO Box 1041
Providence, RI
02901

alhidell@aol.com
joandarc@
compuserve.com

CONTENTS

The Dragons of Eden

2

R. Boulay



The Reptilian Agenda for the New World Order

8

Interview with
David Icke

Stealin' the Show: Disney Influence in the Age of Knowledge

14

Randy Koppang



JFK and the Manchurian Candidate

21

John McLoughlin



Darwin and the Scientific Dictatorship

30

Phillip Darrell
Collins



We All Live in a Yellow Submarine

38

Adam Gorightly



The Hidden Face of Terrorism

46

Paul David Collins



A Funny Thing Happened on the Way to the Moon

52

Bart Winfield
Sibrel



Silent Weapons for Quiet Wars

56

Operations Technical
Manual



What Evil is and Why It Matters

62

John Paul Jones



Paranoia is distributed by: IPD in CA; Ubiquity in Brooklyn; Last Gasp in San Francisco; Bear Family Distributors in Tucson, and Media Solutions. Paranoia is available at all Tower Records stores. All articles copyright 2003 by the author. Cover illustration by Eric White at www.ewhite.com

Deadlines:	Ad Size	W X H	1 time	2+
Feb 1	1/8 page	3 1/4 x 2	\$60	\$51/ea
June 1	1/4 page	3 1/4 x 4 1/4	\$90	\$76/ea
Oct 1	1/2 page	6 1/2 x 4 1/4	\$125	\$106/ea
	full page	6 1/2 x 9	\$200	\$170/ea
	inside cover	7 1/2 x 10	\$250	\$212/ea

Ad Rates

Take a 15% discount for 2 or more insertions! Rates are per issue. JPG or TIF files, or a print-out, are required. If you want us to design and typeset your ad, send us the copy (words) and art and ADD \$15 to the listed cost.

The Dragons of Eden

by R. Boulay

Dragons have permeated world consciousness and are found in the mythology and literature of all world civilizations. Sometimes they take the form of flying reptiles, often times they are flying serpents breathing fire. Usually they are beneficent creatures, but in certain cultures they are considered the source of evil.

A catalog of all the appearances of dragons in the cultures of Europe, China, India, the Middle East and the Americas would be an enormous task. Suffice it to say, the idea of fiery, flying serpents is found everywhere. In many places, it is a substratum of historical traditions. In England, for example, there are over seventy towns and villages that have dragons in their folklore. In China, they are the ancestors of Emperors.

In order to discover their origin, we shall wend our way back through history and follow the trail of the dragon. Our journey in time takes us back through the Medieval Period in Europe, and the early Christian Church.



The Dragon of Mesopotamia

Roman and Greek legends lead us to Asia Minor, where many of their stories originated, and from there we proceed to the Semitic civilizations of the Middle East. We find that the Levant, the ancient name for the lands of Palestine, Syria, Lebanon and Jordan, was an offshoot of the parent civilization of Mesopotamia. As we follow the spoor of the dragon, we travel back to the Assyrian, the Babylonian, the Akkadian, and finally back to the prototype or 'mother' of all civilizations, the Sumerian.

It is here in the myths and stories of

Sumer that we first see references to the dragon. These ancient Sumerian myths were the source of the dragon-slayer motif and many of the stories of the *Old Testament*, such as the Creation of Man, the Fall of Man, and the Fall of Lucifer. It was the manipulation of these legends by the ancient Hebrew priesthood, and later the early Christian Church, which obscured their original meaning and provided the serpent with an evil reputation.

Myth versus History

Man is the only living creature to experience history, for it is his ability to record memory, and to transmit memory from generation to generation, which creates "history." Conventional scholarship insists on a rigorous distinction between "history" and "myth." In this paradigm, history consists of documented facts, such as names, dates, battles, treaties, revolutions, political and social events. Myth, on the other hand, is dismissed as belonging to the realm of fantasy, poetry and fiction. Yet, for people in the past the two were inseparable.

In fact, all myth is derived from historical fact or event. This event is the core that is added to, and embroidered by, successive generations. It becomes their historical fact, that is, their "myth." Written history actually consists of a mixture of fact and myth. The same is true of political, religious and social events. Myth must also be given a certain amount of credence where there is separate historical fact to support it, for instance, archaeological evidence, wall paintings and reliefs, statues, and other artifacts. We all know that "angels" did not have wings, especially the flimsy ones shown in religious paintings. These wings are symbolic of the gods and their minions, of their ability to fly about the Earth and to reach a "heavenly abode." Probably the best example of myth overtaking history is the appearance of the "dragon" in the religious literature of the Judeo-Christian tradition.

It is now accepted as fact that the *Old Testament*, especially the *Book of Genesis*, is an abbreviated version of myriads of documents available to the early chroniclers who assembled the scriptures. Many of these ancient documents are available to the serious researcher, who can choose from a vast amount of pseudepigraphal and apocryphal books, which expand on the stories of the *Old Testament*: a rich Jewish oral tradition that is summarized under the name of *Haggadah*. These numerous religious documents have survived only in languages other than Hebrew, such as Latin, Ethiopic, Slavic, and Coptic.

The Legged Snakes of Eden

According to Genesis and other documents, long before humans existed, the serpent lived in the Garden of Eden and did all the necessary work to maintain it. This Biblical serpent was not just a lowly snake; it could converse with Eve, and knew the truth about the Tree of Knowledge. It was of such a stature that it unhesitatingly challenged the deity. Genesis concedes this point when it asserts that "the serpent was the shrewdest of all the world beasts that God had made."

Ancient Jewish legends describe the serpent of Eden as manlike—he looked like a man and talked like a man. The part of the *Haggadah* that deals with the Creation depicts the serpent who inhabited the garden as an upright creature, which stood on two feet and was equal in height to the "camel." He was said to be the lord over all the beasts of Eden. "God spoke to the

It was the manipulation of dragon legends by the ancient Hebrew priesthood, and later the early Christian Church, which obscured their original meaning and provided the serpent with an evil reputation.

serpent: 'I created you to be king over all the animals. I created you to be of an upright position.'" In the *Haggadah*, there seems to be little doubt that the serpent who inhabited the garden had legs like other animals. Therefore, the many representations of the temptation of Eve, which show it as a snake curled around the Tree of Knowledge, are based on a misunderstanding of the scriptural text.

In the *Book of Genesis*, the serpent was severely punished for his role in the downfall of Adam and Eve. His fate was henceforth to crawl on his belly. In this way, Genesis implies that the serpent was a legged creature, which lost its limbs as a result of the eating of the "forbidden fruit." Sources in the *Haggadah* are more explicit, and plainly state that "his hands and feet were hacked off." In appearance, the legged serpent must have been a fearsome creature, dominating all the animals, as well as man. In fact, Genesis states that when Adam and Eve were expelled from Eden they wore "shirts of skin." These "skins" must have been sloughed off by the reptiles, since many ancient documents verify that Adam and Eve were vegetarians in

the Garden, and humans didn't kill and eat animals until after the Deluge.

Ancient Jewish legends indicate that the clothes worn by Adam and Eve were made of reptile skins, which protected them from predators: "When they wore the coats, Adam and Eve were told, all creatures on Earth would fear them." The serpent skins were symbolic of the ruling race, and not only reminded Adam and Eve of their origin, but also acted as a talisman to safeguard them from wild creatures.

The notion of the serpent as evil is a fairly recent one, which evolved during the early Christian era. The Biblical serpent is often connected with godly knowledge, healing and immortality. The Hebrew word for the creature who tempted Eve is *nahash*, which is usually translated as serpent, but means literally "he who knows all secrets."

It was the *Book of Genesis* that ordained an eternal enmity between reptiles and humans, and the dragon/serpent became the symbol of temptation and evil. In recalling other legends of the dragon's destructiveness, humans were provided with ample excuse to seek out and kill every "dragon" in the land. Dragons, which had been objects of veneration in Greek and Roman homes and oracles, soon disappeared, and were no longer available for transmitting their wisdom.

The Winged Dragons of Eden

Sometimes ancient religious sources allow dragon references to slip through. One such document, called the *Apocalypse of Abraham*, the testimony of the patriarch found only in the Slavonic language and dated to the 1st Century AD, clearly depicts the serpent that tempted Eve as a winged dragon:

And they were standing under a tree in Eden and the fruit of the tree was like the appearance of a bunch of grapes on the vine. And behind the tree was standing something like a dragon in form, but having hands and feet, just like a man's, on his back six wings on the right and six on the left. He was holding the grapes of the tree and feeding them to the two I saw entwined with each other.

The legend of the dragon was quite pervasive in early religious literature. It is seen in another old document, called the *Testament of Solomon*, which refers to the building of the temple at Jerusalem by Solomon. Dated to the 1st Century AD and written in Greek, it describes how the dragon interfered with the construction of the temple. Described as "a wallowing dragon, having the limbs of a dragon and wings on its back, the face and feet of a man," its fiery breath burned up all the wood to

be used in the building of the temple. It also set the forest of Lebanon on fire. Solomon subdued it and put it to work cutting stone for the temple. The idea of a dragon obstructing the construction of the temple seems bizarre to us today, but two thousand years ago it was not so fanciful. It shows the preoccupation of the religious authorities with the symbol of the dragon.

Many of the angels of the *Old Testament* were winged, especially the Cherubim (singular Cherub) and the Seraphim (singular Seraph). In fact, the Seraphim are often described in obscure religious sources as dragons. Probably the

best-known of the dragons in the scriptures is the one found in the *Book of Revelation*, where the dragon represents the great Satan that persecutes Israel and the Christian Church. It is referred to as the "the great red dragon, with seven heads and ten horns and a long tail." According to this book, man would worship the dragon just before the end of the World.

The Seraphim

In the *Old Testament*, explicit references to our serpent-god ancestors have been all but eliminated over the centuries through a long process of selection and editing. When allusions to winged serpents are found, they are usually interpreted as allegorical. However, there is a strange incident related in the *Book of Numbers* concerning a bronzed or brazen serpent, which raises many questions that are not fully addressed by Biblical scholars. During the second year of the Exodus, after the



tribes had left the comforts of Mount Sinai and were struggling across the wasteland, they had a skirmish with the King of Arad in the Negeb. The Hebrews prevailed after much difficulty. The incident of the brazen serpent happened at that time:

The people grew restive on the journey, and the people spoke against the Lord and against Moses, 'Why did you make us leave Egypt to die in the Wilderness? There is no bread and water, and we have come to loathe this miserable manna.' The Lord sent Seraph serpents among the people. They bit the people and many of the Israelites died. The people came to Moses and said, 'We sinned by speaking against the Lord and against you. Intercede with the Lord to take away the serpents from us.' And Moses interceded for the people. Then the Lord said to Moses, 'Make a Seraph figure and mount it on a standard. And if anyone who is bitten looks at it, he shall recover.' Moses made a brazen serpent and mounted it on a standard and when anyone was bitten by a serpent, he would look at the brazen serpent and recover.

It is difficult to escape the conclusion that the meaning of the incident is obviously idolatry, an activity stringently forbidden in the scriptures. The "seraph" of Moses apparently had healing powers, an attribute which appears time and time again with the flying serpent.

The Hebrew word Seraph is an unusual one and appears only a few times in the books of the *Old Testament*. In the *Book of Isaiah*, the Seraph is referred to as *me ofef seraph* or, literally, "flying serpent." It is associated with the Philistines and the Negeb, lands which were traditionally the home of the so-called serpent people, the descendants of the Nefilim after the Deluge. The reference in Isaiah is as follows:

In the year that King Ahaz died came this oracle: 'Rejoice ye not, O Philistia, all of you, that the rod which smote you is broken, for from the serpent's root will come forth an adder, and its fruit will be a flying serpent (*me ofef seraph*). And the first born of the poor will feed and the needy lie down in safety; but I will kill the root with famine and the remnant he will slay.'

This flying serpent appears again in Isaiah 30, when he refers to the land of the Negeb as "a land of trouble and anguish from where came the lioness and the lion, the viper and the *me ofef seraph*." The brazen serpent of Moses, which was made at God's command, was revered in the Temple sanctuary in Jerusalem until the

days of King Hezekiah in the 8th Century BC. According to the *Second Book of Kings*:

In the third year of the reign of Hezekiah he did the following: He removed the high places, and broke the pillars and cut down the Asherah. And he broke in pieces the bronze serpent (seraph) that Moses had made, for until those days the people of Israel had burned incense to it; it was called Nehushtan.

The Asherah mentioned here were shrines to the Canaanite goddess, Astarte, and were representative figures of the goddess mounted on a wooden pole. It apparently stood side by side with the "Nehushtan,"

The Sumerian accounts make it clear that the Adam of the Bible was what one might call Homo saurus, a hybrid mammal-saurian creature that was our ancestor, the first step in the creation of modern man.

which was the brazen flying serpent, also mounted on a pole. Nehushtan is a form of the word *nahash*, that is, the serpent of the Garden of Eden and actually means "he who knows all." It is doubtful that this was the original seraph made by Moses about 1450 BC, and that it survived until this time. In either case, it demonstrates that the worship of the serpent-gods, exemplified by a flying serpent, was well established among the Israelites during the period of the Kings and the Judges. This suggests that Yahweh had at one time been identified with the flying serpent.

The term *seraph* has worried Biblical translators and commentators over the years. It is translated as "fiery serpent" in the King James version of the Bible, but the modern tendency is not to translate the word at all, but to render the Hebrew as given. It is probably borrowed from the Canaanites, who acquired it from their Mesopotamian heritage.

The Seraphim were supposedly part of the heavenly host, and along with the Cherubim and Opannim, guarded the heavenly throne. The Hebrew *Apocalypse of Enoch*, a pseudepigraphic document written in the 5th Century AD, describes the heavenly abode where four Seraphim guard the throne, but do not serve on the divine chariot or Shekinah. These Seraphim have six

wings. This same six-winged creature is also described in the *Book of Isaiah* (6:1-2), wherein the prophet says:

In the year that King Uzziah died I saw the Lord sitting upon a throne, high and lifted up; and his train filled the Temple. Above him stood the Seraphim; each had six wings: with two he covered his face, and with two he covered his feet, and with two he flew.

The early Hebrews apparently equated dragons with flying serpents, which came under the name Seraphim, the "angels" who guarded the heavenly throne. This information is also found in Gnostic documents, which contain numerous references to the Seraphim or "dragon-shaped angels" who were the guardians of the heavens.

The Origin of the Term Seraphim

The roots of the term Seraphim may well be in Mesopotamia. The flying or fiery serpent atop the pole, worshipped for its healing properties, symbolically represents Enki, the Sumerian God of healing, who is often represented by the serpent or snake symbol. There is also a curious resemblance to the snake wrapped around the pole, later used by the Greeks as the caduceus, the symbol of healing. In Sumerian art, the serpent is a symbol of immortality.

In the famous *Epic of Gilgamesh*, the hero is frustrated in his bid for immortality when the gods, through his grandfather, Utnapishtim (the Sumerian Noah), refuse to bestow upon him this gift. Not to let Gilgamesh go home empty-handed, Utnapishtim provides him with information on how to obtain a magical plant that heals and prolongs life. After obtaining the plant, Gilgamesh plans to take it home to Uruk, and to share it with his fellow citizens. On his way home he stops by a pool to bathe, leaving the plant unattended on shore with his clothes. As he is bathing, a snake grabs the magical plant and takes off with it, shedding its skin as it goes, symbolizing regeneration. In this epic, the serpent is called *seru* and the similarity of the word to "seraph" is striking, suggesting a common origin.

The serpent-people (*sarpa*), the Nagas of ancient Sanskrit sources, are said to have inhabited the mountains of India and Tibet. Theosophist, H. P. Blavatsky, published a comprehensive study of these ancient people in *The Secret Doctrine*. She asserts that the *nagas* or *sarpa* of India are "unquestionably the Jewish Seraphim

of the *Old Testament*, as derived from the term *serapi*, meaning serpent."

While these flying serpents or dragons are found in the culture of people throughout the world, they are usually considered to be benevolent creatures, and in

most cases are considered the actual ancestors of man. This is why the European view of the dragon as evil is unique. The evil nature of dragons is prevalent in Jewish literature, such as the Mishnah, the part of the Talmud that is the Jewish commentary on ethical behavior. With regard to permissible pictures or images, dragons are specifically proscribed: "If



Enki, the Sumerian god of healing

one finds utensils upon which is the figure of the Sun or Moon or a Dragon, he casts them into the Dead Sea (a symbol of destruction). Pictures of all planets are permissible except that of the Sun and Moon, and that of the Dragon."

The warning against depicting dragons is repeated in other tractates of the Talmud. While representations of all the other planets are permitted, the Sun, the Moon and the Dragon are specifically prohibited. This is probably due to the fact that the Sun and Moon are associated with Sumerian gods of Palestine and Lebanon: Shamash being the Sumerian Sun god and the Moon being the symbol of Sin, a major god of the pantheon. The dragon, of course, represents the entire Sumerian pantheon, all being reptilian gods.

Denizens of the Garden of Eden

Genesis is not very helpful in identifying the inhabitants of the Garden of Eden. Adam was clearly the first and only "human." Then Eve was created from his "rib" ("TI") to provide him with a mate. Most critics now agree that the creation of Eve from Adam's "rib" was an early Hebrew distortion with the purpose of establishing male dominance. The Genesis type of creation lacks any parallel in Middle Eastern mythology. The Sumerian and Semitic term for "rib" also means "life." The early editors of Genesis either made a whopping error of

translation or purposely distorted the real meaning of TI. It seems more logical that the word TI represents the "life force" or "essence of life," the meaning the Sumerians used when they referred to the creation of man.

Early Christian and Hebrew writings reveal that there were other inhabitants of the Garden of Eden. In the Gnostic view of the creation of Adam, the original occupant of the garden was Sophia, who gave the "breath of life" to Adam, and provided her daughter Zoe as a wife to Adam. In the early rabbinical comments on the Torah, as they are found in the Midrash, the original denizen of Eden was Lilith, and Adam was created to be her mate. She rejected Adam mainly because she would not assume a subordinate or recumbent position in sexual intercourse. She left the Garden of Eden and only then was Eve created as a mate.

According to the *Genesis Rabbah*, a Midrash account of the *Book of Genesis* compiled in the 5th Century in Palestine, Eve was not created from Adam's rib but rather from his tail, which had been part of his body. God cut this off and the stump, now a useless coccyx, is still carried by Adam's descendants. Thus the Adam who occupied the Garden of Eden lost his reptilian tail as a result of the "Fall." Perhaps the stump was left as a reminder to man of his reptilian ancestry by a facetious god.

It would seem that early religious sources believed there were a number of primitives occupying the Garden of Eden, yet, all but two—Adam and Eve—have been expunged from the scriptures. Nowhere is there a mention of the creation of offspring. Therefore, as in the Sumerian accounts, the denizens of Eden must have been "clones": creatures formed or created individually by the hand of the creator god. Also clear in religious accounts other than Genesis is the dominance of the female image, the "mother of all living," as was often said of Eve. The symbolism of the mother goddess, representing fertility and the mother Earth, is completely missing from Genesis, and may have been deliberately eliminated.

Homo saurus, Primitive Man of Eden

In the epics of Mesopotamia, Man's creation was secondary, and even incidental, to the creation of the Universe and to the colonization of this planet by alien visitors. Man's creation was conceived and executed not as an end in itself, or as a natural development of the civilization of Mesopotamia, but rather as an expedient to satisfy a group of discontented aliens. Man's purpose was to serve the gods; man was meant to be the breadwinner, the laborer, and the caretaker of the gods.

The Sumerian accounts make it clear that the Adam of the Bible was not the *Homo sapiens* of today. He was what one might call *Homo saurus*, a hybrid mammal-saurian creature that was our ancestor, the first step in the creation of modern man. In just a few years, man had taken a quantum jump in evolution. He had suddenly evolved from the wild ape-man to a hybrid that would become a new species known as Cro-Magnon Man.

The hybrid that was created probably looked reptilian, since he was created in the image of his gods. Genesis is very specific about this, for it states, "then God said 'I will make man in my

image, after my likeness.'" Later, as man intermarried with his species, the reptilian strain deteriorated and he became more mammal-like, and less and less reptilian in appearance. The mammal genes dominated the reptilian ones and man became more "human" and less god-like. This explains Man's "sinful" nature and his "fall from grace." Original sin was man's deviation from the basic reptilian or godly pattern.

Genesis repeatedly makes the point that before the Fall, while he occupied the Garden of Eden, man was naked. It was not until he ate of the "forbidden fruit" that he realized he was naked and put on clothing. Other ancient religious sources support this condition of man, but they also reveal the reason why he was naked. According to the *Haggadah*, the bodies of Adam and Eve "had been overlaid with a horny skin," and, moreover, of Adam it was said his skin "was as bright as daylight and covered his body like a luminous garment." Adam, thus, had the outward appearance of a reptile, with its bright, shiny skin. It was for this reason that the first created humans did not need clothing for protection or comfort.

The *Book of Genesis* also makes it clear that Adam did not sweat while he was in the Garden of Eden. That was his punishment for eating the forbidden fruit, for he was told, "by the sweat of your face shall you earn your bread." Adam did not sweat before the Fall for the simple reason that sweating is characteristic of mammals and not reptiles.

As long as they remained in the Garden of Eden, Adam and Eve also did not propagate. Strangely, they were unable to reproduce their own kind. The "Fall of Man" was the ability to procreate by taking on the traits of mammals. It is explicit in Eve's punishment that she is to bear the pangs of live birth, like a mammal.

The above illustrated points are probably best explained by a tract from a Gnostic document. The statement found in early Christian literature, that Adam and Eve "saw their makers and loathed them since they were beastly forms," makes it abundantly clear why the Gnostics were persecuted by the fathers of the early Church, who declared following Gnosticism to be punishable by death.♦

R. Boulay is the author of Serpents and Dragons, published by The Book Tree (www.thebooktree.com). Call (800) 700-TREE for a free catalog. See advertisement on front inside cover for more details.

David Icke Interviewed
by Joan d'Arc and Al Hidell

The Reptilian Agenda for the New World Order

Contrary to popular opinion, the mysterious publishers of *Paranoia* on rare occasions are seen out and about in public. David Icke's first east coast conference, held in Boston in February 2002, was one of those rare events. David Icke is the author of several books on the reptilian agenda for planet Earth, including *The Truth Shall Set You Free*, *Children Of The Matrix*, and *The Biggest Secret*.

We received an invitation to David's first Boston talk from the kind fellow who sponsored the event, who asked us to bring along some copies of *Paranoia* to sell to the audience members. Expecting some British stuffed-shirt to drone on about the reptilian bloodlines of the Queen Mum, what we actually got was an energetic, down-to-Earth, riotously funny bloke, who sounded as though he'd have been just as comfortable raving from a barstool. David Icke's enigmatic presence was a delight! His slide presentation was hilarious. If you have a chance to see Icke, don't pass it up.

After we returned from lunch, we experienced the strangest sensation when we looked around the historical theatre and saw that almost everybody in the place was reading a copy of *Paranoia*. We thought we were in a surreal dream, but we couldn't figure out whose dream it was! Just before the magazines sold out, we made sure the sponsor pulled out a couple of issues to give to David. A short time later, David agreed to do the following interview while he was completing his new book, *Alice in Wonderland and the World Trade Center Disaster*.

Joan d'Arc: David, it was nice to get a chance to see you in your first east coast talk. Was it a success, and will you be coming back to Boston again in the near future?

David Icke: I do not see events as a success or failure, they just are. I give information and people accept what feels right and leave the rest. How they receive it is not my concern nor any of my business. The numbers coming to my talks have soared over the last 12 months as people open their hearts and minds to another version of reality. I have been asked to go back to Boston and maybe it will happen later this year [2003].

JD: Why is it that after all these years you never spoke before in the northeast? Is there something different about the people on the east and west coast? What I'm getting at is, you seem to be straddling the "New Age" crowd and the "conspiracy" crowd. How in your view do these groups differ, and do they respond to your ideas in different ways?

DI: I don't align with any group, because if you can give what you believe a name then you are in a prison of the mind. Everything just is; it doesn't answer to a name. I simply speak where people ask me to speak. The visit to the northeast took so long because no one asked me before. The so-called "New Age" and the "conspiracy" researchers have been polarities for a long time, and one of my motivations is to fuse the spiritual with the scientific and the street-wise. I can see this happening because my

audiences come from all shades of colour, race, background and belief. Let us unite on our common bonds, not disunite over differing perceptions of reality. What is reality anyway?

AI Hidell: Some of the most fascinating parts of your lecture dealt with clues that can be seen all around us in the form of architecture, art and symbols. Could you describe some of the symbols our readers might be likely to find in their own city or town, or see on TV, and what they mean in relation to the global controllers?

DI: I go into this in some detail in my book, *The Biggest Secret*. The manipulators, or "Illuminati," have their own language of symbolism, which they place all around us. Sometimes these symbols relate to their own ritualism and other times they are designed to subliminally "talk" to the human subconscious. For example, the Illuminati goddess way back in Babylon was Queen Semiramis, the "branch bearer." The way they symbolized her thousands of years ago was a mirror of the Statue of Liberty, which was given to New York by French Freemasons in Paris, who knew the true significance. She is holding the lighted torch because that is the most classic of all Illuminati symbols—the Illuminated ones—Illuminati. The goddess Columbia is the same and so is the goddess of the French republic to this day. On an island in the River Seine in Paris is another mirror image of the Statue of Liberty for this reason.

AH: In 2002, Americans were horrified by a series of seemingly unrelated child kidnappings and murders. Do you think there is more to the story that has not been revealed? Could you also describe the purpose of elite ritual child abuse, as it pertains to your theories?

DI: This is a massive issue that cannot be detailed in a few sentences. However, it was no coincidence that while America was having a spate of child kidnap-

pings and murders, so was the UK. As a result, many parents here are agreeing to have their children micro-chipped to protect them. This is the technique I have dubbed "problem-reaction-solution," in which you create the problem so you can then offer the solution—changes in society that suit your agenda. Micro-chipping is the jewel in the crown of the agenda because of the control it would give them over human thought and emotions. The Illuminati also engage in massive child and other human sacrifice today, as they always have. Why they do this needs a lot of explaining, which is why my books run to five hundred pages or more.

JD: Did you have trouble coming to grips with the bizarre occult aspect of Earth's political situation? Did you ever consider that you might have fallen off your rocker?

DI: Not really, because it unfolded to me gradually over the last decade and not all at once. I have a simple research technique: I follow the evidence, and my own intuition constantly leads me to that evidence. I also realize, as Socrates is supposed to have said, 'wisdom is knowing how little we know.' This keeps the mind open to going places that closed minds would not consider. It also helps that I don't give a damn what people say about me.

AH: What motivated and motivates the entities that you believe control our world? In other words, what's in it for them?

DI: Fear of not surviving. They equate control of everything with a better chance of survival.

AH: Is the Earth unique in this regard, or is this phenomenon found throughout the universe?

The Illuminati goddess in Babylon was Queen Semiramis, the "branch bearer." The way they symbolized her was a mirror of the Statue of Liberty, which was given to New York by French Freemasons.

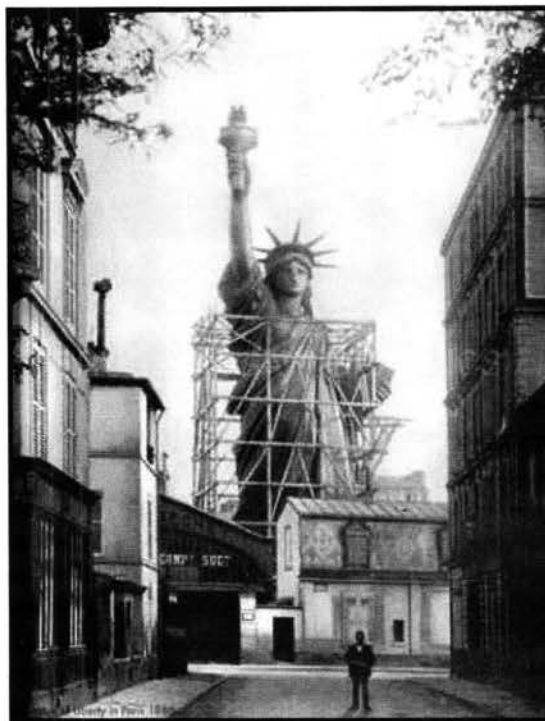

DI: Actually, it is not only the Earth we are talking about, but the whole of “physical” reality. The movie, *The Matrix*, is the best visual representation of our plight that I have yet seen. We live in a dream world, believing it is “real.” I’m just starting a new book that will go into this in detail, because understanding the nature of reality and the creation of reality is to understand the game far more than just looking at secret societies and all the rest. These are just “this world” expressions of a much greater picture. [However, actions in “this world” can have very real and serious consequences—Eds.]

AH: Some people agree with you “up to a point,” and that point usually comes when you introduce the concept of shape-shifting reptilians. Are they an indispensable part of your world view, and if so, why? Could the systems of global control that you have so clearly illuminated exist with only human controllers?

One of the ancient symbols for “infinity” is the snake swallowing its own tail. The period we are now experiencing has been played out before. We are like a rat running on a wheel in a cage. We need to break the “time” circle and thus the prison.

DI: I don’t write or talk for people to agree or disagree with me. I will not argue a point because I’m not trying to convince anyone. If people find the reptilian aspect a problem, they should believe something else, it doesn’t matter to me, nor, I repeat, is it any of my business. These reptilian and other “entities” operate from a frequency range very close to this one, but just out of the range of the human five senses. They manipulate this “world” through human bodies by what has become known through history as “possession.” They take over the mental processes of the “human” body and these are the guys in the major positions of power.

But this is only one level of the story. It is much bigger than that and these entities are just pawns of another force also. Could purely human controllers in this “dimension” have manipulated humans to the same end over thousands of years? No. The other-dimensional level is the common

theme that has continued the coordinated agenda while “human” Illuminati operatives have lived and died throughout the period in question.

JD: What are you discovering in your current research that has not been revealed before? Can you give *Paranoia* readers a little hint about what to expect from your present book?

DI: My latest book is *Alice in Wonderland and the World Trade Center Disaster: Why the official story of 9/11 is a monumental lie*. The title speaks for itself, the official story is a joke and does not stand up at any point. The horrors of September 11th were orchestrated within the borders of the United States, not from a cave in Afghanistan. It was done to create the excuse (problem-reaction-solution) for the explosion of control, surveillance and destruction

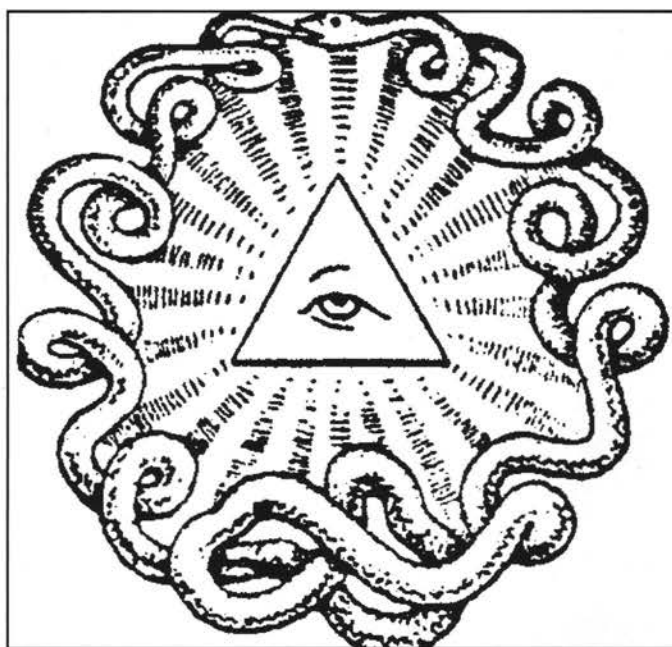

of privacy that was introduced literally within days, and has continued ever since. Without 9/11 there would be no war on terrorism, which is being used to take over the countries essential to oil and oil extraction from the Caspian Sea.

But the reason is much bigger than just oil. The Bush family is fundamentally involved, as my book reveals. The book I’m starting now is about the next level of the story beyond this “world,” and beyond reptilians and anything I have written about so far. •

**David Icke’s website is
www.davidicke.com**

Behind the Bloodlines

Only by understanding the nature of reality can we answer the obvious question that comes from the information I present about the bloodlines and how long they have been manipulating this five-sense reality. The question is why would people dedicate their lives to the plan for global domination when they knew they would be dead long before the goal was reached? What if the entities controlling the bodies of those in power through the ages have largely been the same ones all along? What if they operate just beyond the frequency range of the five senses and use apparently "human" physical bodies to manipulate the five-sense world? What if when one body gives up on them at "death" they just move into another and continue the manipulation, the long-term agenda, for another period of "time"?

The area of research that people find most difficult to comprehend is that the bloodlines placed in the positions of power throughout the world are not "human" in the sense that we understand that term. I appreciate why people find that so difficult because being caught in the five-sense illusion includes being subconsciously programmed to believe that if you can't see it, it doesn't exist. I have revealed in considerable detail in my last two books, *The Biggest Secret* and *Children Of The Matrix*, the staggering number of people, both ancient and modern, who have told of the same experience—seeing an apparently human being, often people in power, transform in front of their eyes from a human entity to that of a reptilian entity. Others

have seen the same transformation, a phenomenon known as "shape-shifting." The reptilian form is by far the most common form.

To the conditioned five-sense reality, this idea is crazy, bizarre and ludicrous. If people wish to believe that, go ahead, it makes no difference to me. But are those people saying only that which they have seen with their eyes or has been accepted as real by official sources can exist?

People will just have to believe what they want to believe. I have no desire to convince anyone of anything. But after all these years of full-time research, which has taken me to 40 countries, thousands of people and countless ancient and modern accounts, it is clear that this "world" or frequency range, the five-sense prison, is manipulated from the outside by non-human entities that take over or "possess" the apparently human bodies of the Illuminati bloodlines.

Between dimensions, in this case between the third dimension (the five-sense prison) and the next one, the fourth dimension are little "crevices" of frequency. The Italian physicist, Giuliana Conforto, author of *Man's Cosmic Game*, calls them "inter-space planes," and they lie between the dimensions. The scientists in the Horizon program called them parallel universes. It is in the inter-space plane, Giuliana suggested to me, that these reptilian and other entities reside. This is the realm of

the "demons" of folklore that have been frightening and manipulating humans for as long as ancient accounts go back. [...]

People who have taken mind-altering drugs that break through the vibrational walls of the five

In more recent times, these bloodlines have moved out of overt positions of power because people no longer stand for that form of rule. Now they dominate the population in another way: through politics, banking, business and media ownership.

senses have had the same experience. Also, if these entities lower their vibration only slightly to enter the five-sense range, they become visible to us here. Those who have experienced Illuminati blood sacrifice rituals have also told me

many stories of seeing this “shape shifting” transformation among the participants. As the Horizon science program said about parallel universes, “The only explanation that anyone could come up with is that the particles don’t just exist in our universe. They slip into existence in other universes too, and there are an infinite number of these parallel universes, all of them slightly different.”

If it is possible for particles to move between universes of realities and dimensions, so it is possible for entities, consisting of particles, to do the same. This is a major reason why the Illuminati bloodlines have taken part in these rituals from ancient times to the present day. The rituals allow them to connect with their masters in the inter-space planes. Credo Mutwa has described to me how he witnessed rituals decades ago at which people in the room shifted from human to reptilian form. [...]

This brings us to the reason why the Illuminati are obsessed with bloodline.

Thousands of years ago, indeed aeons probably, a non-human race interbred with humans to create hybrid bloodlines. This story is told in every native culture and such sources retain far more of the true history of human existence than the “history” taught in today’s schools and universities. We even see expressions of these accounts in that amalgamation of ancient writings we know as the Old Testament. This story tells of the sons of the gods who interbred with the daughters of men to create a hybrid race, the Nefilim. The accounts say that the Nefilim caused mayhem wherever they went.

Different versions of the Nefilim story with a common theme can be found all over the world. Credo Mutwa, for instance, refers to the

Nefilim as the Chitauri—Children of the Serpent—because this non-human race takes a reptilian form. Insiders have confirmed to me that the world is indeed controlled by bloodlines that are reptilian-human hybrids. By “insiders” I mean those who work for this network against their will, those who have experienced its privileges and diabolical rituals before turning against it, and those who have been victims of its grotesque agenda and mind control projects.

The ancient idea of Divine Right to Rule originates from this interbreeding. The “divine” right does not relate to “God,” the Infinite Spirit, but to the “gods,” the non-human entities involved in the interbreeding. They came to be known as the “dragon bloodlines.” Chinese emperors claimed the right to rule through their genetic connection to the serpent gods. Still today we have “royal” families around the world who come to the throne solely because of their DNA. In more recent times, these bloodlines have moved out of overt positions of power because people no longer stand for that form of rule. Now they dominate the population in another way; through politics, banking, business and media ownership.

The DNA is the body’s genetic blueprint and can have a massive effect on behavior. One consequence of this corruption is that these bloodlines do not have the same emotional responses as the rest of the earth people. They are not subject to the same emotional fallout: killing thousands in the World Trade Center or in Afghanistan or in Iraq is no emotional

challenge. It’s just another day’s “work,” another step on the road to global domination. [...]

In the movie, *The Matrix*, you will recall how the “agents, who were manipulating the masses and controlling the computer-generated illusion, could come in and out of the world by moving in and out of different human bodies. The same principle applies to the reptilians and other entities in our five-sense plane. [...]

The major players in the Illuminati and those behind 9/11 and the “war on terrorism” are reptilian inter-space entities occupying human form within the five-sense world. They are not “American” or “British” or “Chinese.” They are entities manipulating through those physical forms and have no allegiance to the people they “lead.” [...] They are beings of thought and ritualistic instinct. More than that, their aim is to cause slaughter and pain because of the energy this generates. •

Excerpted with permission from: *Alice in Wonderland and the World Trade Center Disaster* by David Icke.

Alice in Wonderland and the World Trade Center Disaster

Why the official story of 9/11 is a monumental lie

David Icke





Issue 21

BACK ISSUES!

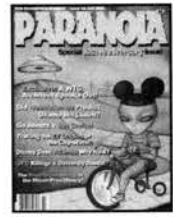

Issue 30

All back issues are now \$7, shipping included. Send payment and issue numbers to: Paranoia, Box 1041, Providence, RI 02901-1041, or order online at www.paranoiamagazine.com.

Special Offer: Issues 1-30 for \$150 (\$210 value) plus get a free copy of *Paranoid Women Collect Their Thoughts*. Offer good while supplies last! *Please allow 3 weeks for personal checks to clear. MO is faster.*

- Issue 1:** Copy only
- Issue 2:** Jonestown Death Cult by John Judge, Drugs & the CIA, The Umbrella Man, AIDS Genocide
- Issue 3:** Who Killed John Lennon?, Feminism's Hidden History, Danny Casolaro, Face on Mars
- Issue 4:** Waco Secret Weapon, Leonard Peltier, Traffic in Human Organs, KAL007, Jack Kevorkian, Mystery of Alternative 3
- Issue 5:** Virgin Mary & UFOs, Satanic Child Abuse, Yetis & the CIA, Cattle Mutilations, Lindbergh Kidnapping, Leary, Manson & the CIA
- Issue 6:** Masonic Symbolism in the JFK Assassination, UFOs & the Black Death, Clinton Body Count, Death of River Phoenix, William Cooper
- Issue 7:** R.B. Cutler on Chapquiddick, Roots of the KKK, Rock and Roll Satanists, Is Cancer Contagious?, Reich & UFOs
- Issue 8:** Bill Baird's Abortion Wars, UFOs in Puerto Rico, Newt Gingrich: Liberal, The Four Horsemen of the Apocalypse, Israel's Hidden History
- Issue 9:** Dan Rather, CBS, and JFK, OKC Bombing, Japanese Gas Attacks, Alien Corpse in Puerto Rico, Tijuana Cancer Clinics
- Issue 10:** Nuclear Omnicide, The HAARP Report, OKC Aftershocks, Gemstone File, How to Build a UFO
- Issue 11:** Mind Control Cults, Fatal Vision Murders, Colin Powell Exposed
- Issue 12:** Subliminal Sex in Advertising, The Goatsucker, Hidden Facts behind JFK Autopsy, Shirley Mac Laine and the NWO

- Issue 13:** MOVE Firebombing, David Bowie: Space Oddity, Greg Little Explains EMF-UFO Theory, Murder in the Vatican
- Issue 14:** JFK and Tippit, Monarch Mind Control, Cancer Cure Cover-Up? Star Trek: Sci-Fi or Psy-War?
- Issue 15:** Hoax Issue! We Never Went to the Moon, Crop Circles, Is Paul McCartney Dead?, Alternative 3, Nazi UFOs
- Issue 16:** Larry Flynt, Who Killed Yitzhak Rabin? EMF Weapons, Gulf War Syndrome & AIDS, Satanism & the Illuminati, The Knights Templar
- Issue 17:** History of Modern Mind Control, Psy-Ops & UFOs, AIDS is Man-Made, Hale-Bopp & the Green Horse
- Issue 18:** Princess Diana & Ritual Murder, USOs, Secrets of a Vatican Insider, Nuking of America, Operation Garden Plot
- Issue 19:** Implant Victim Robert Naeslund & CIA Sex Slave Cathy O'Brien, The Other Lewinsky Tapes, Evolution Hoax Exposed
- Issue 20:** Skull & Bones, UFO Robot Probes, Breeder-Bloodline Cults, AIDS-ET Connection, Anorexia & Occultism
- Issue 21:** Killer Water Microbes, Remote Viewing Exposed, Aleister Crowley, Why We're in Yugoslavia, 3rd Reich of Dreams
- Issue 22:** Hughes, Onassis and Gemstone, Is Fluoride Killing Us?, Christ Conspiracy, Grail Bloodlines, JonBenet, The Matrix & Bob Dobbs
- Issue 23:** Who Killed Dorothy Kilgallen? Planet X: What is NASA Hiding?, Magikal Roots of Nazism, Richard Boylan on UFO Secrecy

- Issue 24:** All-Girl Issue! The Death of Diana, Karla Turner, Mind Control Technology, Network of Stolen Consciousness by Beth Goobie
- Issue 25:** Who Killed Jimi Hendrix? Illuminati at the Movies, Mind Control Update, Beth Goobie Pt. II, The Aviary & the Eschaton, UFOs & Vieques
- Issue 26:** Planet X: The Messianic Star, The Police State, Politics & the Occult, Racism & the Drug War, Marcel Vogel & the Secret Fifth Force
- Issue 27:** Sci-Fi as Manipulation, AIDS Blame Game, Darwinism's Hidden Agenda, The Chupacabras, Endgame of ET Exposure, Candy Jones and Mind Control
- Issue 28:** Behind the War on Terrorism, 9/11 Media Spectacle, Kent State & Nixon, Bush-Cheney Drug Empire, Symbolism of Nibiru
- Issue 29:** NFL's Hidden History, Nazis, Iraq & the OKC Bombing, Psy-Ops & Sci-Fi, Anthrax Mailings, Alchemists & Planet X, Freemasonry & the Twin Towers
- Issue 30:** Gaudi & Ground Zero, Nostradamus and bin Laden, Killer UFOs, Spy Cruise, Kent State and Nixon, Disney & Futurism, Pagan Origins of Christianity
- Issue 31:** Jung & Flying Saucers, Animal Mutilations, Israel & 9/11, Thought Control in Education, Examining the Psychs, West Nile Virus, Illuminati Agenda
- Issue 32:** Moon Hoax, DC Sniper, Gods and Water, "Lost Years" of Jesus?, Nibiru and Dead Sea Scrolls, 9/11: The State Terror Thesis, Homeland Security*

Stealin' The Show!

Disney Influence Upon Entering the Age of Knowledge

by Randy Koppang

Part Two of *Stealin' The Show* further details the perception of America as an "idea." It's an environment of potential, where innovators like Walt Disney can realize futuristic social visions. Social historians William Irwin Thompson and Jean Baudrillard have critiqued the cultural impact of Disney entertainments, and both recognize how Disney alters traditional aesthetics of history via simulation media.

In visiting the "time machine" that is Disneyland, your port of entry is in the past. Seizing visitor attention with a "spatialized" era in time amuses them with familiar pastimes of nostalgia. Past times are, thus, a vehicle where Disney begins "imagineering" the visitor through landscapes of fantasy, frontier and adventure: qualities which interest people in the possibilities of social progress. Ultimately the public "inner-child" is prepared for Disney's futurism of Tomorrowland or EPCOT. The time machine is an appropriate metaphor for Disney's innovation: the invention of a space for amusing people in the now—with memories and imagination—culminating in their future. This was Walt Disney's passion.

Author Ray Bradbury studied and wrote about Disneyland. Realizing Walt was a futurist role model, the Fall 2001 edition of *The 'E' Ticket* magazine featured Bradbury's personal account entitled, "Walt Disney and Other Memories of the Future." Bradbury concluded, "Walt was not an optimist (in his entertainments). He was an optimal behaviorist ... he cared about urban planning, and cities of the future." Bradbury felt, "Disneyland was a perfect example of design and planning ahead for the human ..." because "Disney did all kinds of things that didn't

have to be done ... (surrounding) people with beauty, that isn't necessary."

Disney's most practical exhibit of futurism is the monorail. Bradbury lobbied for a Los Angeles municipal monorail with his citizens group, "Save Rapid Transit and Improve Metropolitan Environments." Disneyland's monorail was the model for this. Bradbury said, "the psychology of the monorail is what makes it superior." Beyond the mundane, Disney advocated futures in space. Bradbury said Disney "loved history." Disney made history by being "one of the first, with his *Man In Space* television series, to care about space ... even more than the people in Congress."

From Perfect City to a Perfect Civilization

History-making and Disney projects continue in his afterlife. This is where history and alterity ironically converge in Disney's mainstream public image. The Disney name is not readily identified with reshaping history, yet in the *idea* of America, breaking ties with the past is concomitant with freedom. So it was that on June 10 and 15, 2001, Walt Disney Co. credibly validated a new history. Breaking with prevailing authority, Disney presented mythologized Atlantis as fact! Its feature film, *Atlantis, The Lost Continent*, was advertised with its

TV-documentary of facts titled, *Voyage to Atlantis*. For Disney, Atlantis is the greatest success story.

Ray Bradbury wrote "Disneyland is a perfect city" in which "you can learn from the totality of the experience ... (on) how to treat people." When considering Disneyland as a microcosm, as an experiment of city management, what model can we imagine Disney using to symbolize "the perfect civilization"? The answer is Atlantis. Disney's documentary, *Voyage to Atlantis*, repeatedly defines Atlantis as "the perfect civilization." In this, Disney's futurism employs historical revisionism. But why? Two contradictory perceptions of history-making present a paradox: the linear vs. the non-linear. In light of any viable space-faring program going nowhere fast, which future is currently being actualized for us? Disney has advocated a non-linear move to our past in Atlantis as a model of our future.

Secret Destiny of America

From the time of the Sumerians, memories of a past Golden Age have persisted. The Freemasonic founding fathers of America knew that any social-structural assets of an idealized Golden Age should not be usurped by the genealogical elite of Europe. During the Constitutional Congress, they reviewed the practical models America might adopt. Manly P. Hall writes, in his book *The Secret Destiny of America*, Plato's *Critias* and Sir Francis Bacon's *New Atlantis* could be read as foibles, if you didn't know any better. According to Hall, the *Critias* "describes the government of the Golden Age."

The case for Atlantis has now been addressed in philosophic tradition by Disney. In so doing, Disney validates Plato and Bacon's descriptions of "the perfect civilization" as Atlantis. Any assets from a historical (Atlantean) Golden Age should be retrieved to benefit a new civil development; a social achievement that up until the 21st Century was held as occult knowledge by Theosophists, Rosicrucians and Freemasons. What has entered history here is advocacy of a new aesthetic paradigm on a global scale. Yet, consumerist / reductionist materialism can't get out of its own way. Thus, on 11/28/01, George Bush said he was going "to do whatever it takes to insure that *this civilization* remains intact." Unfortunately for those committed to such a narrow "tunnel of reality," globalism is an opportunistic exploitation of our global village in order to dominate and sell more crap. It's obsolete! Time to move on.

Those studying occult percepts of earth history may find it no coincidence that the push is now on to reconcile with Atlantis as a new reality. Currently, young adult members of re-tribalized rave culture have been producing a series of massive Atlantis dances,

transforming the "legend" into a meme for utopian multiculturalism.

For a mainstream institution like Disney to advocate Atlantis as a "perfect civilization" accentuates the inadequacy of our own. For Disney's documentary to say "sometime in history we got it right ... maybe we can get it right again" is perhaps suggestive. Do they know we've run out of options, intuitively or otherwise? Current 9/11-related

Middle Eastern events confirm this every day. The policy perspective of Western Civilization is 19th Century: America playing out subconscious archetypes in a Hegelian environment of adversarial dialectic of them vs. us. This spell cannot be broken by good people wedded to the current consensus paradigm. Disney does base its profits on the consensus world-view, but Disney is subtly advocating a new aesthetic paradigm. More

important, Disney's advocacy does not depend wholly on its views of Atlantis history. There's more.

Disney's Tomorrow Includes ET Today

History shows a cyclic pattern. As in the age of Gutenberg, the chaos we now see globally is a function of a "divided world that (is) dissolving and resolving at the same time." (McLuhan, *Gutenberg Galaxy*) Earth has moved into a perceptual framework where three or four dimensions give way to hyper-dimensional realities. Our continuum is necessarily multi-dimensional: it is where the human haunting of a mythologized "Other" originates. Like Atlantis, the "Other" reserves a preeminent place in the panorama of facts censored from history.



"Everything changed" our narrow reality tunnel in 1947. Even for those members of society in denial or uncompromisingly skeptical of ET evidence, "ET" remains a formidable meme of change. As with Atlantis, purveyors of "authority" try as they will to segregate ET into scientific

advanced Atlantean civilization are not credible issues; they are *non-issues*! In deciding to become a mainstream proponent of such antithetical issues, Disney might seem out of character. Such advocacy clearly does not comport with the Christian-Americana of family values with which conservatives prefer to symbolize Disney's image. Is this a paradox? The secret to Disney's successful legacy was observed by Orson Welles in a bio-account of his dealings with

Walt Disney. Disney possessed means to "appeal directly and powerfully to the ... vast audience." Having an innate *savoir faire* when securing the interest of his audience, "Orson once said of the mass audience, 'Once they are interested they understand anything in the world.'" (Leaming, 272, 283) Apparently, Disney Co. knows its audience and how to interest them.

Thus, there is continuity. Disney's *Atlantis* intends to educate, validate the premise and promote a product. Like *Atlantis*, *Alien Encounters* ascribed no time or value for dissuasive (disinforming) skepticism. There was none! This preempts creation of controversial debate around the issues. Debates waste time! Evidence for both ET and Atlantis is cumulatively

clear, and Disney recognized it. The promo angle for *Alien Encounters* was to advertise its EPCOT-Tomorrowland attraction of the same name, while organizing a mini-UFO conference at EPCOT, in tandem with the *Alien Encounters* documentary.

Disney's Kitschian Time Machine

All this illustrates the insight that Disney Co. seized two transcendent perspectives of human potential and mirrored them back with its stamp of approval. The advantage in seeing Disney assume a role in such matters is the progression toward mainstream acceptability on the issues of ET and Atlantis. This was a step toward credibility for mass consumption, which research at the "fringe" or the New Age could never hope to achieve. This is how I define 'Stealin' *The Show*': mass marketed Global Theatre with anti-historical content interfacing the hearts and minds via mixed corporate media. Revisionist perceptions at the fringe are not going to mass market anything, and the media is the primary force affecting ratios of perception, as Marshall McLuhan instructs.

The theme here is futuristic change in America. Disney couldn't be more timely, lending credibility to how ETs and Atlantis fit into its kitschian time machine. In the *Alien Encounters* program, Robert Urich proclaims, "Now, as we approach the new millennium, mankind is in the midst of the most profound event in history! Actual contact with intelligent life from other planets ... many (people) still refuse to acknowledge the obvious evidence all around them. Would it be enlightening? Would it be an experience in terror or, perhaps, both?" Hence, Disney's intent somehow involves preparing people for "profound event(s) in history."

Folks like to think of Disney as a trademark of apple-pie Americana. As a businessman, Walt Disney's corporate image is that and more. Orson Welles, in his direct experience with Disney and Dis-

Disney's remedy for dehumanizing modernity was to merge a "hot" medium (cinema) with a "cool" medium (animation). ... It appears that Disney chose the medium of animation with which to imprint his audience.

explanations of myth or misidentified foolishness. To their chagrin, the dogma of authority and academia only inflames controversy, and popularizes actual experience in the lives of all peoples, throughout time. As with Atlantis, our persistent taboo memories are now being accurately validated.

On 3/25/95, Disney Co. took another stand with a prime-time documentary called *Alien Encounters*. Using the same implicit revisionism as in its Atlantis program, *Alien Encounters* again contradicted mainstream "science"; this time regarding ET visitations. Disney CEO, Michael Eisner, introduced the *A.E.* broadcast saying, "With more and more scientific evidence of alien encounters and UFO sightings, the idea of creatures from another planet might not be as far-fetched as we once thought." The *A.E.* program was a corporate production that made philosophical assertions contrary to mainstream tolerance. As *Alien Encounters*' host, Robert Urich, stated in the prologue to the show, "From distant galaxies, intelligent life is now attempting to make open contact with the human race. Tonight we'll show you the evidence."

From the cryptocracy of pop culture, questions of ET visitations or a highly-

ney's associate, Nelson Rockefeller, said "Disney was a ... neo-Fascist." (Leaming, 272) It is also known that during a period of exaggerated patriotism, Disney was an informant to the FBI. However, such an accusation cannot censure Disney's genius for popularizing values of human potential. Another paradox?

Hot and Cold: Occult Media Effects

Paul W. Roberts, in his critique on Disney for *Kabbalah* magazine, reported that Disney's "treatment of folktales and fairy stories ... shows an innate understanding of their potency, which derives from the many levels of meaning to be found" by all people, "depending on the times ... in which they" viewed the films. This "potency" is elaborated by Roberts as *esoteric* insight imbedded *within* fairy tale literature.

These esoteric contents are kabbalistic truths of universal simplicity basic to the unlikely media of children's tales. Disney then amplified the epochal popularity of these tales. As a note of interest, in his book *Magick in Theory and Practice*, Aleister Crowley lists *Alice in Wonderland* as recommended reading for those studying kabbalah. Disney animated children's tales in a medium that exteriorizes visual faculties; he projected stream of consciousness. As we shall see, somehow Walt Disney perceived that animating the virtues of children's tales is a remedy for modern human alienations.

As McLuhan instructs in *Understanding Media*, "Film and the stream of consciousness alike seemed to provide a deeply desired release from the mechanical world of ... uniformity ... men seemed, by stream of consciousness or interior film, to obtain release into a world of spontaneity, of dreams, and of unique personal experience." A remedial reconnection with "imagineered" spontaneity and "natural" play were key Disney objectives, as his futurism became an anti-environment to the disservices of modern life.

Paul W. Roberts credits a story on Disney from a 1954 issue of *Saturday Evening Post*. Roberts described Disney's view of modern man as having "lost the sense of play he once had and he inhibits physical expression. He's the victim (of civilized ideal) ... even gestures get to be calculated ... the spontaneity ... gradually trained out of them." In New Age terms, Disney saw society alienating itself from its Inner Child. Behavior had become more robotic. In *War and Peace in the Global Village*, McLuhan places great emphasis upon this disservice of modern times: a robotizing behavior modification lived out within densely technologized environments. Disney's esoteric animation, then his theme parks, are what Ray Bradbury referred to as "optimal behaviorism."

In McLuhan terms, Disney's remedy for dehumanizing modernity was to merge a "hot" medium (cinema) with a "cool" medium (animation). As McLuhan explains in *Understanding Media*, "A hot medium ... extends one single sense in 'high definition.' High definition is the state of being well filled with data ... A cartoon is 'low definition' simply because very little visual information is provided." It appears that Disney chose the optimal medium of animation with which to *imprint* his audience. Values of wisdom in fairy tales would lose their symbolic impact and esoteric simplicity in the hyper-realism of live action. As McLuhan explains,

"Any hot medium allows for less participation than a cool one."

Select fairy tales shown in animated 70mm Technicolor and Cinemascope immerse viewers in participatory imagination, cinematizing themes of a literary tradition; a tradition usurped by electric media. Since Disney's first film, *Steamboat Willy* (1923), succeeding generations became less and less literate. McLuhan describes our time as an era of post-literacy. Thus, Disney demonstrated his genius for futuristic applications. If esoteric literature offers occult knowledge, Disney's approach to the occult is via the exoteric means of our time: cinema, not books. However, as disclaimed by Paul W. Roberts, "It is not my intention here to present Disney as an adept in some occult tradition with a mission to elevate human consciousness by hermetic means. But I do suggest that his natural genius amounts to the same thing."

Precisely! And to this I would add that Disney is playing out an unlikely and heretofore unacknowledged destiny. As a function of Disney's personal legacy, his company is now demythologizing the esoteric roles played by ETs and Atlantis in human history. Disney's mass-media services the polis, revising history by entertaining "you" with facts censored by omission. This service is consistent. In reviews of early Disney productions, critics observed how his *Three Little Pigs* or *Snow White and the Seven Dwarfs* served "to humanize and soften the industrial world," or to "present a 'tonic for disillusion' among common people in a world beset by wars, crime, and economic strife." (Roberts, 44) Now, the Company carries on.

Disney and Esoteric Mysteries

Currently, Disney has moved on from mundane issues to the esoteric Mysteries. The element of magic is now Disney's trademark; for instance, the Magic Kingdom and transformations made by Tinkerbell's magic wand. Thus, Disney has helped make Magic a meme, a symbol of identity, an imaginative constant of awareness. This became all the more conspicuous (or less occult) when Disney chose to factually upgrade ETs and Atlantis, since the technological implications of ETs and Atlantis also lead to magic.

Quoting Arthur C. Clark, "Any sufficiently developed technology would be indistinguish-

able from magic." To the uninitiated, magic is merely fantasy. To students of the Freemasonic mysteries and growing numbers of the New Age, magic is a means whereby experience is non-linear (not limited to 3-D causes), perceived and co-created via the subtle energies of either the conscious or unconscious will. The

ET or Atlantis facts must be reconciled
with the histories we thought we knew.

America is the only social venue for
popularizing what once was myth. And so
far Disney is the only "institution" with
courage to speak out.

reality you live is the reality you co-create. In bringing Magic into the limelight, Disney goes beyond metaphor and speaks to those whose perceptions of reality are evolving, those who know magic is an actual phenomenon.

Paradoxically, as Paul W. Roberts writes, "We know much about Walt's social values, yet little about his spiritual ones, beyond the fact he had no time for orthodox religion of any kind." (Roberts, 46) This is obvious. Religious symbolism does not enter Disney content, but "virtues of community" and "triumph of the underdog," as well as futurism and magic, do. As Roberts also notes, *Fantasia (the Sorcerer's Apprentice)* and other Disney films "abound with arcane symbolism that demonstrates a thorough familiarity with the mystical sources for these stories (with) roots in Hindu mythology and Persian folklore."

Disney's Americana

What does all this portend, futuristically? The options are sure to have some macro-micro order to them. In 2001,

Disney World's *Electric Parade* commemorated Walt's birth year as "100 Years of Magic," stating that, "the Orlando property is ... geared more to the adult now ... including the Disney Institute's vacation-with-courses." (Roberts, 46) Orlando is where the *Alien Encounters* exhibit resides. Disney Co. is getting into motivation as well as education. Clearly, its socio-corporate history is subtext to the Americana it alone symbolizes. In the world of mixed-corporate media, there are all other companies—and there is Disney. Its socio-imagining is comprehensive: from its role in Celebration, Florida, the actual model-community; to its recent buyout of The Baby Einstein Co., which develops products (media) that expose babies to language, arts and science; to extending Einstein's "Baby" series to a series for preschoolers; to acquisition of the Fox cable channels as a secondary outlet for ABC network programming; to being the world's largest publisher of children's materials.

Disney is a major player of perceptual influence in the World Game. Perhaps its prescription for survival can be symbolized by the difference between basic profiteering vs. *imagining*, as well as a form of post-modern pioneering. Disney's global expansionism may be like Alice's mirror in Wonderland: the theme parks are largely mirrors of memory. Through the vanishing point in the mirror, viewers enticed with curiosity ultimately confront sci-fi futures becoming fact.

The unifying principle is the heterogeneous dissolving of boundaries in America itself. Walt Disney said, "Disneyland will never be completed ... (it) is dedicated to the ideals, the dreams, and the hard facts which have created America." So it is, by 2005 the global tally of Disney parks will total eleven. In this expansion, Disney will reach beyond boundaries with a formula for balancing "expected Americana with native sensibilities" (Schneider). The "balance" is a ratio of liberated Disney-Americanism to local traditional folkways; for instance, energies of harmony/discord were balanced at Hong Kong Disneyland via construction compliance with *feng shui* principles.

Disney's America is an arena for reconciling the known and unknown with new perceptions. America is history in the making. But the American "ideals" and "hard facts" that Disney emphasized are acultural and non-traditional. They are American. The prerequisite for the liberating "idea" of America is *free-thinking*. America is a paradox: the corporate-political interests violating ideals of freedom have contradicted its potential, yet, America's implied freedoms are historically exceptional.

Freethinking imagination led to Disney asserting in its ABC-TV documentary that, "For nearly fifty years, officials have been documenting routine alien encounters here on earth. And thousands of people have seen or experienced this alien presence." These ET facts, or Atlantis facts, must be reconciled with the histories we thought we knew. In terms of mass public appeal, America is the only social venue for popularizing what heretofore was myth. Thus far, Disney is the only "institution" with courage to speak out.

Discerning Disney's Role

Disney Co. is, like any corporation involved in global-trade politics, not perfect. Cultural historians like Jean Baudrillard and William Irwin Thompson have critiqued Disneyism and Americana. In his book, *America*, Baudrillard notes that both USA and Disneyland evoked an approach/avoidance response in him. His French-Europhile aesthetics reactively realized how America has become not a cultural progeny of a founding immigrant heritage, but an *anti-environment* which simulates Euro-cultural history. "It is, therefore, in America and nowhere else that modernity is original," he states. Baudrillard perceives that in this American simulacrum, "there is no culture," ... it's "the disappearance of history." American rights of expression are a license to simulate contexts of historical memory with recombinant "wildness." In our land of "anything goes," Baudrillard recognized "the pure baroque logic of Disneyland," a microcosm of a "televisual" hyper-reality.

For Baudrillard, American styles of reconstituting Euro-artifacts are inauthentic, banal. It's the marketing of parody as paradox in "Disneyland glitter." This simulation of history in media exaggerates affects. These affects, however, could serve to neutralize or dissolve the iron-clad sense of possessive and exclusive cultural identity to which Americans are conditioned. Indeed, Disney's *Atlantis* film characters are intentionally multicultural. Disney's *Atlantis* dynamically pushes the envelope. It consistently appeals "directly and powerfully to the ... vast audience." The given is that we live our communication-lives at the light-speed of electricity. The revolutionary re-programming of ethnocentric awareness toward trans-cultural identity moves too fast for habits of tradition.

William Irwin Thompson's critiques of America and Disney are similar to Baudrillard's. Both hold Euro-aesthetic precepts of history. But Thompson's concern is media-effects, whereas Baudrillard's is comparative and Euro-centric. Their Euro-literary bias ("visual space" in McLuhan terms) is crucial to recognition of a factor missing from their paradigm: it's now time "for something completely different" in terms of American histrionics.

Thompson critiques "Disneyism" and America with near cynical dissatisfaction. In his book *At The Edge of History*, his search for history shifted from Europe to Los Angeles, concluding that "through the artificial monuments he sees nearby in Disneyland ... there is no history to be seen or experienced in any meaningful way," in or outside Disneyland. True! Yet Thompson presumes too much about what history *seems* to be. The current mystique of contradictions he and Baudrillard articulate so well are an index for discerning patterns of paradigm change: the "replacement" of a linear historical logic with fantasy or simulation, which mirrors our shapeshifting reality via media. Similar change occurred between medieval and modern eras. Now, we are changing from postmodern to post-postmodern. As McLuhan put it, "poised between ... a divided world ... dissolving and resolving at the same time."

In his book, *The American Replacement of Nature*, Thompson devotes a chapter to Disneyism. He suggests, "The cultural implications of EPCOT are that this non-community is a real polity. One that actually performs the transition from plutocracy to mediocracy. A society of the mediocre bonded together by the entertainment media. This new polity is one in which 'democracy' becomes an

artifact ... (one) of fantasy participation in the electronic State." This is only partly valid because he extrapolates in speculation.

Baudrillard perceives America's historicity a bit more profoundly, saying "Octavio Paz is right (that) America was created in the hope of escaping history." Thus, as Thompson says of Disney's *discontinuity*, "Mississippi riverboats, medieval castles and rocket ships equally fill the reality of a single moment." (Thompson, 12)

The Imagineers

Disneyland is a microcosm of internet-satellite-TV effects surrounding and mirroring earth—all histories made accessible simultaneously as "the reality of a single moment." Most people on earth live psychosocial realities hundreds of years into the past, and futuristic living standards have only been made partially available by design. So, history is discontinuous in the sense that Eastern philosophy advises living in the moment, not the past or future. Disneyland resonates such nested historical realities as an experience of esoteric insight—for fun! At this stage of Disney's futuristic career, it's unlikely that the Imagineers don't realize the perceptual impact of synergizing past/adventure/fantasy/frontier and future in the momentary Gestalt of *fun*! If they don't realize it, so much the better. The genius of Disney's influence is not hyper-real Hollywoodism, it's animation of the esoteric. This is why Disney's structure of a theme park also serves as a *memepark* for esoteric values.

Disney provides a service. But Thompson criticizes Disney's audience as a "civic religion," even though Walt had no use for religion, *per se*. No clear ideology prevails in Disneyism, apart from insuring brand loyalty. The plot thickens. In Disney's *Alien Encounters* documentary, host Robert Ulrich declares, "We must prepare you for the future with some shocking insights from the recent past." That was in 1995. The future *A.E.* prefigures, however, is quite alien to the portent of America's undoing five years later. Now, in 2003, "shocking insights" abound with 9/11 warmongering and corporate scandal everywhere.

The *Alien Encounters'* "future" accords with Walt's own value for the "hard facts" that created America: free speech and public

accountability. Disclosure of ET/Atlantis facts is not the P.R. policy of an institutionalized "cover-up mentality." Not surprisingly, then, Disney's ET/Atlantis documentaries resonate directly with earlier acts Walt made regarding both issues. As I wrote in Part 1 (*Paranoia*, Issue 30), Atlantis facts relate to Disney futurism. Consider Walt's own words regarding his Tomorrowland as quoted in the 1964, *Walt Disney's Guide to Disneyland*:

Fact or fancy, 'Flying Saucers' nonetheless also have a place in Tomorrowland. Our newest adventure includes 64 individual Flying Saucers." ... "In Tomorrowland, you'll explore the mysteries of liquid space aboard authentic submarines (built with assistance of General Dynamics Corp.) ... to view the Lost Continent of Atlantis ... and you'll board a rocket ship to blast off into outer space.

This is comprehensive continuity—imaginative inner space, liquid space, outer space. Disney subtly revises historical awareness in a drama of cognition which redefines aesthetic values. Our conveyance into this new order is a mysterious path. When *media* displaces traditional aesthetic reference points—i.e. European—it leaves one feeling "everything has disappeared"! Which form will our new paradigm take? Jean Baudrillard said of his Europhile perspective, "The mystery of American reality exceeds our fictions and our interpretations." (Baudrillard, 98)

Archeology Confirms Atlantis

Unlikely news events point to Manly P. Hall's *Secret Destiny of America*. America and Atlantis do share a common destiny. Disney ended its *Atlantis* documentary with breaking news on an archeological discovery, which could only relate to Atlantis history quite close to American shores. In the "Science File" of the *L.A. Times* for 4/1/02, a subtle headline read, "Investigating Possible Sunken City Off Cuba." It reported, "Scientific investigators" pursue what "could be a sunken city from a previously unknown ancient civilization ... Cuba's Natural History Museum has joined a Canadian exploration company in efforts to solve the mystery of the smooth geometrically shaped, granite-like ... structures resembling pyramids, roads and other structures in a 7-3/4 mile-square area."

Disney's *Atlantis* documentary concludes with this news story. The pyramidal structures, Disney reports, are not ambiguous, but they do sit at a depth of over 2,000 feet. Such a depth contradicts the average estimated increase in sea level since the last "ice age," which is 300 feet. A lost city submerged at 2,000 feet legitimates an earth history previously held as occult knowledge of Theosophical adepts. Theosophists posit that four catastrophes reconfigured Atlantean geography, occurring at about 800,000; 200,000; 80,000; and 9,564 BC. (Scott-Elliot, 3)

A text of required reading for Freemasonic initiates states the original founders possessed scientific knowledge comparable to the modern physicist, and that the origins of Freemasonry "leads back to the ancient Mysteries." It asks, "do candidates realize they are performing a rite originated by Adepts in the Mystery temples of ancient Atlantis, whence the Mystery tradition sprung, and in ancient Egypt?" (Hodson)

Appreciation of occult science, inferred by any sincere treatment of Atlantis, is synonymous with Atlantis as fact. Disney's animated *Atlantis* film culminates in an epic scenario that represents the role occult crystal-science plays in Atlantean lore. It is the initiation into popular awareness of an esoteric historical dimension, where mysterious components of human racial identity can be reconciled. Disney's *Atlantis* is both a historical and spiritual education. Disney has simply acted (not reacted) responsively to the Zeitgeist of aesthetic movement in this direction; fleshing out the unknown is what the new paradigm order symbolizes.

With Disney's inclusion of ET, Walt's "bastion of the American mainstream" commands a media vantage for *Stealin' The Show*, a role that was destined to be assumed somehow by somebody. It's doubtful there exists any other institution whose capability or demonstration of initiative would transgress popular notions in such an unorthodox direction. •

References

- Baudrillard, Jean, *America* (London: Verso, 1989).
- Ferrell, David, "'Gray Ghost' Harbors Some Ghoulis Tales," *L.A. Times* (Feb. 14, 2002), p. B2.
- Hodson, Geoffrey, *At the Sign of the Square and Compasses* (The Eastern Federation International of Co-Freemasonry, 1976, 1986).
- Klinkenborg, Verlyn, "Wonderful World of Disney Guiding Light," *L.A. Daily News* (Dec. 7, 2001).
- Leaming, Barbara, *Orson Welles* (Viking Press, 1985).
- McLuhan, Marshall, *The Gutenberg Galaxy* (Canada: University of Toronto Press, 1962).
- McLuhan, Marshall, *Through The Vanishing Point* (New York: Harper Colophon Books, 1968).
- McLuhan, Marshall, *Understanding Media* (New York: McGraw-Hill, 1964); *War and Peace in the Global Village* (McGraw-Hill, 1968).
- Roberts, Paul W., "Walt Disney: Prophet of Human Potential," *Kabbalah* (May/June 1998).
- Schneider, Mike, "In The Right Place," *L.A. Daily News* (Dec. 29, 2001).
- Scott-Elliot, W., *The Story of Atlantis* (London: Theosophical Publishing Society, 1896).
- Thompson, William Irwin, *At the Edge of History* (New York: Harper Colophon Books, 1971); *The American Replacement of Nature—Play: "Disney's World, The American Replacement of Culture,"* 1991.

Randy Koppang is a researcher and media ecologist, who has authored several articles on a comprehensive set of topics for *Paranoia*, *Perceptions*, *Flipside*, *Atlantis Rising* and on the website www.xenochrony.net. He can be contacted via email at the.occupant@horizon.net.

JFK and The Manchurian Candidate

by John McLoughlin

President Kennedy was assassinated as a result of the hatred and bitterness that has been injected into the life of our nation by bigots.

— Chief Justice Earl Warren, *Dallas Morning News*, 11/23/63

Chief Justice Warren was 100% correct on this score. During the year 1963, there were almost two dozen separately identified threats against the life of President John F. Kennedy that were deemed important enough to be investigated by various Federal or State law enforcement authorities.

Pay special attention to threats emanating from right-wing extremists in America, individuals formerly belonging to groups like the Congress of Freedom, the Liberty Lobby (founded by Willis A. Carto), the National States Rights Party (NSRP), to which Joseph A. Milteer belonged, and the Anti-Communist Liaison Committee of Correspondence (ACLCC), founded by Charles A. Willoughby, and his associate, Dr. Edward Hunter, a self-professed Nazi, who actually coined the term “brainwashing.” Take special note of the number of former members of the John Birch Society, including Robert J. Morris and Dr. Revilo P. Oliver, who are mentioned in this comprehensive list of Kennedy stalkers, character assassins and conspirators during Kennedy’s last year on earth—1963.

After briefly reviewing the history of several disrupted attempts on the life of JFK, in the cities of Chicago, Los Angeles, Nashville, Miami, New Orleans and Dallas, I will discuss

the only recorded instance following his death in which some of the alleged conspiracy plotters were overheard discussing the murder of JFK. From the descriptions of the persons attending a post-assassination meeting in Winnipeg, Canada, and from snippets of conversations overheard by an informant, Richard Giesbrecht, I have finally been able to recreate their identities at a confidence level well above 95%.

I will also perform the same type of analysis on an important 1958 novel, *The Manchurian Candidate*, by Richard Condon, suggesting that Condon knew the names of more than a dozen persons involved in the creation of programmed assassins as part of the CIA’s MK/ULTRA programs organized and funded via the H. Smith Richardson Foundation, Jim Angleton and Dr. Hans J. Eysenck of The Pioneer Fund. I have determined the identity of not only the person who was *the* “Manchurian Candidate” in Condon’s novel, but also the person who was the ringleader at that post-assassination meeting of the conspirators in Winnipeg overheard by Giesbrecht. Originally I thought these were two different people. Now I am convinced that both Richard Condon and Richard Giesbrecht were describing *one and the same person*, Anastase Andreivitch Vonsiatsky, which makes this Manchurian Candidate thesis a self-corroborating and internally consistent one. When I began this arduous journey almost ten years ago, I had no idea this could possibly be the final outcome.

Plots to Kill the President

Perhaps the first recorded instance of an assassination plot against JFK was documented by Mae Brussell. It occurred before 1960, when JFK was being considered the front-running Democratic candidate for President of the United States. Mae Brussell and Bill Turner are the JFK researchers generally credited with originating the unified conspiracy theory regarding direct involvement of Nazis, neo-Nazis, fascists, and right-wing extremists, like Robert J. Morris and Charles A. Willoughby, in the plot to eliminate JFK. Mae Brussell, Bill Turner and Richard Condon were the first persons to identify Robert J. Morris, ex-McCarthyite and former John Bircher, as one of the lynchpins in the Kennedy assassination conspiracy. The fact that these three authors reached identical conclusions, acting independently and using separate sources and methodologies, lends additional credence to their individual results.

In the early 1990s, Dick Russell, author of *The Man Who Knew Too Much*, published a letter from his mysterious Canadian informant regarding the participation of a person named Adolph Tscheppe-Weidenbach in the JFK plot. The Americanized name of this aide-de-camp to General Douglas MacArthur—who was depicted in a wall-mounted portrait in the opening scenes of the film, *The Manchurian Candidate*—was Major General Charles A. Willoughby. Willoughby was one of the primary movers and shakers in several right-wing organizations active in character assassination attempts on Kennedy. MacArthur called Willoughby, “My Little Fascist.”

Douglas MacArthur was, on at least three occasions, the reluctant presidential candidate of several right-wing extremist factions, beginning in the 1930s with the Smedley Butler coup attempt against FDR, and ending with the 1952 election won by Eisenhower. In the movie, *The Manchurian Candidate*, the contrived name of the person running for president opposite the candidate targeted for assassination was Benjamin K. Arthur. MacArthur’s father’s name was Arthur and his maternal grandfather was named

Benjamin. The movie version of *The Manchurian Candidate* thus begins and ends with direct or indirect references to General of the Armies, Douglas MacArthur who is NOT mentioned anywhere in the Condon novel.

Following is Mae Brussell’s description of the first plot against the life of John F. Kennedy, first published in *The Realist* on November 22, 1983 (1):

Before the election of 1960, a group within the Christian Right plotted to kill John Kennedy in Van Nuys, CA, while he was still a candidate. The group was a meld of anti-Castro Cubans, Minutemen and home-grown Nazis. Some were sought by Jim Garrison, following his arrest of Clay Shaw, for testimony before the New Orleans grand jury. When Garrison forwarded extradition papers for Edgar Eugene Bradley, a member of the group, Governor Ronald Reagan refused to sign them. (This was the first and only time in history that a California governor refused an extradition request from any State’s Attorney or District Attorney.) The leader of one of these groups, the Christian Defense League (CDL), was the Reverend William P. Gale. During the war, Gale had been an Army colonel in the Philippines training guerrilla bands. His superior officer was Willoughby. By the late 1950s, Gale was recruiting veterans for his ‘[Christian] Identity’ group, which was financed by a wealthy Los Angeles man.

One of the CDL’s contacts was Captain Robert K. Brown, a special forces professional from Fort Benning, Georgia. Brown was working with anti-Castro Cubans, mercenaries similar to [Otto ‘Scarface’] Skorzeny’s teams. (Skorzeny was known as Hitler’s Favorite Commando.) Brown is now publisher of *Soldier of Fortune* magazine and paramilitary texts such as *Silencers, Snipers and Assassins*. The book explains how Mitchell WerBell, II (himself a well-known expatriate Russian Czarist, just like Warren DeBreuys [who became an FBI Agent and worked on the Oswald case] and George deMohrenschildt) made special weapons for the CIA, Bay of Pigs assault squads and other customers. WerBell, son of a wealthy Czarist cavalry officer, perfected a silencer so effective a gun can be shot in one room and not heard in the next. It is ideal for assassinations.

Gil Jesus describes several different assassination plots against JFK in Chicago, Miami, Los Angeles, Nashville and New Orleans (gjjmail@aol.com, reprinted by permission):

On April 4, 1963, a Miami Police informant reported on plans by Cuban exile groups to direct their acts of violence, previously reserved for Castro (including murder) against members of the U.S. Government. The exiles were responding to Kennedy’s crackdown which started on March 30. Believing the U.S. government had “turned against them,” the exiles were regrouping into new factions and proposing a series of “actions,” including “a complete disregard for Federal, State, and local authority,” and “the bombing of Federal agencies.” According to a Miami PD informant, “all violence hitherto directed toward Castro’s Cuba will now be directed toward various government agencies in the United States.” In their call to “all our fellow countrymen,” the Fort Jackson Commandos, Cuban exiles who had received special training under the CIA and the Army, said, “we are already organized and fighting again for the liberty of Cuba.

They weren't the only ones threatening violence. Wealthy right-wing extremists from across the U.S. met for the annual Congress for Freedom in New Orleans on April 4-6. At that meeting was another Miami PD informant, who reported that the COF membership included "ranking members of the Armed Forces that secretly belonged to the organization." The informant went on to report that in various speeches, "it was indicated the overthrow of the present government of the United States" was necessary. To achieve this, "criminal activity" was proposed "to assassinate particular persons." Those "particular persons" were the Kennedys and Dr. Martin Luther King.

Kennedy Visits Nashville and Los Angeles

When Kennedy visited Nashville, Tennessee, on May 18, 1963, another threat materialized. At Overton High School, a man approached the President with a gun hidden in a sack. He was grabbed by the Secret Service and the incident was kept quiet to keep from encouraging similar attacks. (*Nashville Banner* 1/23/92)

On June 5, 1963, President Kennedy headed for the West Coast and stopped off to meet with Governor Connally and Vice-President Johnson at the Cortez Hotel in El Paso. A Texas political trip had been stalled by the governor and the conservative machine in the state, which didn't want him there. However, the President was persistent and the governor was forced to yield to his wishes. The final decision to go to Texas was agreed upon. After the final plans were made, right-wing extremist, Colonel Chesley Clark, allegedly told ultra-right professor, Dr. Revilo Oliver, of a likely "communist" conspiracy to kill the President before Thanksgiving. This was likely a complete fabrication on the part of Oliver. The "psywar" had begun.

The Secret Service, tipped off about a possible attempt on the President's life by Cuban exiles during his trip to Los Angeles, arranged for JFK to spend eighteen hours aboard two aircraft carriers at California's China Lake Naval Ordnance Testing Station. To stall for time, the President was "given a look at virtually every weapon in the Navy arsenal." He and Mrs. Kennedy were heading to Los Angeles to attend the Beverly Hilton premiere of the movie *PT-109*, starring Cliff Robertson. It was the story of how JFK saved his crew after his PT boat had been cut in two by a Japanese destroyer. For security purposes, the President and First Lady were flown from China Lake to the preview by helicopter, which landed on the roof of the Hilton.

Oswald, the FBI Informer

On June 24, 1963, a group of anti-Castro Cubans arrived in New Orleans from Miami and joined a training camp off Lake Ponchartrain near New Orleans. Members were from the International Anti-Communist Brigade (IAB), established by Frank Sturgis and Gerry Patrick Hemming. They joined members of the paramilitary right-wing Minutemen. Oswald joined Dave Ferrie at the camp with this group. It was here that Oswald met Arnesto Rodriguez, a Cuban exile who ran a Spanish language school. Rodriguez acted as an interpreter, and was

one of the controllers of funds for the Free Cuba Committee, the group financed by William Reilly.

Two days later, on June 26, a 22-year old unemployed Richmond, Virginia, man named James A. Hawkins was arrested in Mobile, Alabama, on a charge of threatening bodily harm to President Kennedy. On the previous Friday, Hawk-

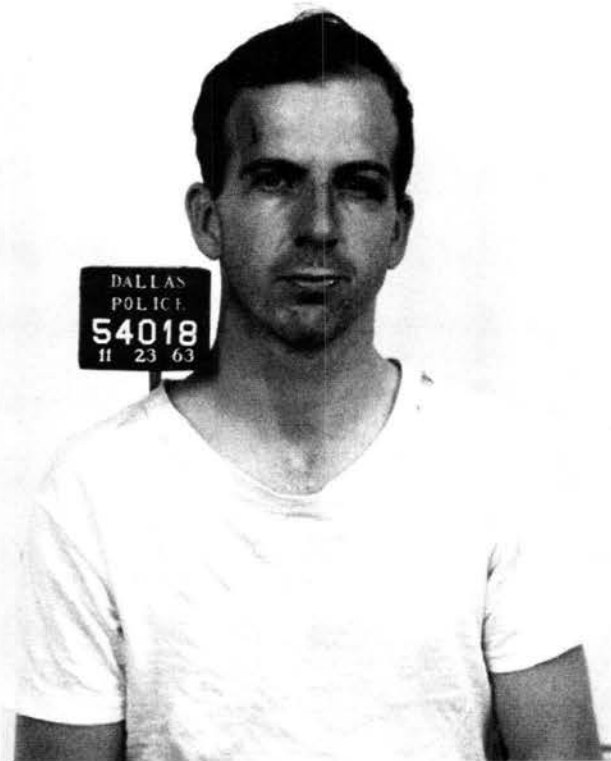

The Man Who Had No Idea: Lee Harvey Oswald, FBI informer, framed by a right-wing cabal as killer of President John F. Kennedy. In October 1963, Army cryptographic code operator, Eugene B. Dinkin, ("The Man Who Knew Too Much") warned the President would be assassinated and blame would be placed on a "Communist."

ins had been walking in Laurel, Maryland, carrying a bag when he stopped at a service station for directions to Washington. During a conversation with the station attendant, Hawkins criticized Kennedy's civil rights program and said he was going to Washington "to blow up the White House and kill the President." The attendant then called the state police, who stopped Hawkins and searched his bag, to find that it contained only clothing. They released Hawkins and reported the matter to the Secret Service, who

obtained an arrest warrant from a federal judge in Baltimore. When Hawkins fled south to Mobile, the Secret Service issued a "pickup order." At his hearing, Hawkins claimed he was "only joking." His trip to Mobile, he said, was to visit friends and relatives.

On June 31, one week after Oswald had visited the camp at Lake Ponchartrain, the FBI raided a home near the camp. They seized more than a ton of dynamite, bomb casings and napalm material. The home was owned by William McLaney, who was connected with organized crime. Within days, the exiles found out through Guy Banister that Oswald had "ratted" them out. Banister ran the Anti-Communist League of the Caribbean, which was part of the World Anti-Communist League (WACL). Banister had received his information from Russian expatriate FBI Agent, Warren DeBreuys, who had been assigned to the New Orleans field office and was monitoring the movements of both pro- and anti-Castro Cubans in that area. Being in the FBI office, DeBreuys was in perfect position to know what Oswald had been informing on. He notified Banister that Oswald was a security risk. He warned that if Oswald got to know the right people within the exile community, he may discover the plot to kill the President.

With his connections in the Office of Naval Intelligence, Banister was able to examine Oswald's military intelligence file. In addition, DeBreuys provided him with copies of Oswald's two FBI files—his security file and his informant file—which indicated Oswald had been an FBI informant since June, 1962. Angered over what they perceived as Oswald's betrayal of their cause, the exiles and Banister decided to set-up Oswald in an operation designed to publicly portray him as being a Castro sympathizer. Oswald, who had no idea that they were on to him, was told that this "publicity campaign" was part of the plan to weed out the Castro agents within the exile community.

The Radical Right

A White House memorandum prepared for the President, dated August 15, 1963, estimated that the radical right spent as much as \$25 million annually, supported by about 70 foundations, 113 corporations, 25 utility companies, and 250 identifiable individuals. It further examined the Conservative Society of

America (CSA), organized by Kent and Phoebe Courtney of New Orleans in June, 1962. Kent Courtney, a personal friend of Guy Banister, had been the National States' Rights Party (NSRP) candidate for Governor of Louisiana in 1960. The memo noted that the CSA "claims a membership of several thousand, located in 47 states." Among those said to be associated with the CSA was "Major Charles Willoughby of the District of Columbia." It also went on to describe H.L. Hunt as being "a frank champion of plutocracy, and reputed to be the richest or second richest man in America." In a Texas speech, Hunt said, "It is just as well that the Cuban invasion failed, because it was just one communist government taking over another."

During the last week of August, 1963, Jerry Russell Craddock, a graduate student of the University of California, Berkeley, met with a friend named Robert Brown, who would later found *Soldier of Fortune* magazine. At the time, Brown was a captain in the School Brigade at Fort Benning, Georgia. Brown told Craddock that while in California raising money for anti-Castro activity, he was in contact with the NSRP. It was during this period that he became acquainted with Dr. Stanley Drennan. According to an FBI memo, Brown told Craddock that while a guest in Drennan's home, the doctor spoke about the possibility of killing Kennedy. Drennan allegedly told Brown the NSRP needed a group of young men to get rid of Kennedy, the cabinet, and all of the members of Americans for Democratic Action. (see Mae Brussell) This was similar to plans discussed at the Congress of Freedom rally in New Orleans (discussed earlier), which was attended by Dr. Revilo P. Oliver and Joseph Milteer in early April of 1963.

In September, 1963, John Richard Salisbury, an engineer with the Brown & Root construction firm in Houston, visited a relative of his named Robert Norris. Norris was a law clerk employed by the Hunt Oil Company in Dallas and claimed to be close to H.L. Hunt. During the visit, Norris stated that "if Kennedy comes to Texas, he will get shot or killed." In addition, Norris said that the only way to get rid of Kennedy was to kill him, and that Kennedy was taking over complete control of the government.

Cuban Exiles in Dallas

The bitterness of the Cuban exiles against Kennedy was illustrated in a tape recording of a meeting between former members of the John Birch Society and Cuban exiles in the Dallas suburb of Farmer's Branch, on October 1, 1963. The speaker was a Cuban identified as Ernesto "Nestor" Castellanos, a pilot during the Bay of Pigs invasion, who vehemently criticized Kennedy's policy of "non-interference" with regard to the Cuban issue. Holding a copy of the September 26 edition of the *Dallas Morning News*, featuring a front-page account of the President's trip to Texas in November, Castellanos vented his hostility without restraint:

Castellanos: We're waiting for Kennedy the 22nd, buddy. We're going to see him in one way or the other. We're going to give him the works when he gets to Dallas. Mr. good ol' Kennedy. I wouldn't even call him President Kennedy. He stinks.

Questioner: Are you saying that since this downfall (of democracy) came through the leader (Castro) there (in Cuba), that this might come to us?

Castellanos: Yes ma'am, your present leader (Kennedy). He's the one who is doing everything right now to help the United States become Communist.

Little did Castellanos know that his comments were being taped by an informant for the Dallas Police Intelligence Unit.

The Man Who Knew Too Much

In March 1962, Army private first class Eugene B. Dinkin was assigned to the 529th Ordinance Company in Metz, France, as a cryptographic code operator. After enlisting in the Army in 1961, he had received his training at Fort Gordon, Georgia. His assignment made him part of the National Security Agency. One of his duties as a code-breaker involved deciphering telegraphs originating with the OAS, the French right-wing paramilitary organization that had tried to kill DeGaulle.

As detailed by Dick Russell, in *The Man Who Knew Too Much*, on October 22, 1963, Dinkin claims, he wrote to Attorney General Robert Kennedy warning: "an attempt to assassinate the President would occur on November 28th; that if it were to succeed, blame would be placed upon a Communist or a Negro, who would be designated the assassin; and believing that the conspiracy was being engineered by the military, I did speculate that a military coup might ensue. I did request of the Attorney General that he send a representative of the Justice Department to Metz, France to discuss this warning." A few days later, Dinkin began to wonder if his warning would reach RFK or be intercepted.

On October 25, 1963, Dinkin attempted to contact several European ambassadors who he had hoped would carry his message. No one replied, which increased his paranoia. He had heard through the grapevine that he was to be locked up as psychotic. On November 2, after receiving stamped approval for a leave, he was called back to the Commanding Officer's office, where he was told his leave was cancelled. Concealing the stamped pass, he tore up a blank one. The following day, he used the stamped pass to leave Metz by train bound for Switzerland. On November 6, unable to get his warning through diplomatic channels, Dinkin told his story to the owner-editor of the *Geneva Diplomat*, warning that "they" were plotting against Kennedy and that "something" would happen in Texas. That evening, Dinkin left Switzerland for Frankfurt, West Germany, where he again told the story, this time to the editor of *Overseas Weekly*, who didn't believe him. The editor advised Dinkin to return to his unit before his AWOL charge was converted to a desertion charge.

Dinkin journeyed to Bonn and arrived at the U.S. embassy, where he was asked to prove the authenticity of his leave. Unable to do this because of his AWOL status, he then left the embassy without conveying his message. Unable to warn Kennedy of the danger, Dinkin returned to his unit in Metz. He was arrested and spent the next five days in jail. On November 13, 1963, he was transported to a closed psychiatric ward at Landstuhl General Hospital until after the JFK assassination, and then transferred to Walter Reed Hospital in D.C. (2)

The Chicago Threat

At the end of October, 1963, the Chicago Secret Service received an FBI teletype detailing a plot by four Cuban gunmen to kill Kennedy in Chicago with "high-powered rifles" during a motorcade. The President was scheduled to visit there on November 2, to attend an Army-Navy football game. On November 1, two suspects were arrested and detained by the Secret Service in Chicago.

In addition to this threat, Thomas Arthur Vallee, a vocal Kennedy critic and former member of the John Birch Society, was arrested by the Secret Service in Chicago, after a search of the vehicle he was driving revealed an M-1 rifle, a handgun and three thousand rounds of ammunition. Vallee had asked his employer for the day of Kennedy's motorcade off. When arrested, he had been driving a car with New York plates, number 311-ORF.

The Miami Threat

On November 9, 1963, Miami Police informant, Willie Somerset, recorded a breakfast meeting with his friend Joseph Milteer, who outlined the assassination of President Kennedy. Milteer was taped by Somerset as he spoke of Kennedy's coming visit to Miami on November 18:

Somerset: "I think Kennedy is coming here on the 18th to make some kind of speech. I imagine it will be on TV."

Milteer: "You can bet your bottom dollar that he (JFK) is going to have a lot to say about the Cubans, there are so many of them here."

Somerset: "Yeah, well, he'll have a thousand bodyguards. Don't worry about that."

Milteer: "The more bodyguards he has, the easier it is to get to him."

Somerset: "Well, how in the hell do you figure would be the best way to get him?"

Milteer: "From an office building with a high-powered rifle."

Somerset: "Do you think he knows he's a marked man?"

Milteer: "Sure he does."

Somerset: "Are they really going to kill him?"

Milteer: "Oh, yeah, it's in the works. Brown [Jack Brown, Imperial Wizard of the Ku Klux Klan] himself. Brown is just as likely to get him as anybody in the world. He

hasn't said so, but he's tried to get Martin Luther King, Jr."

Prodded for more information, Milteer continues:

Milteer: "Disassemble a gun. You don't have to take a gun up there, you can take it up in pieces. All those guns come knock down, you can take them apart."

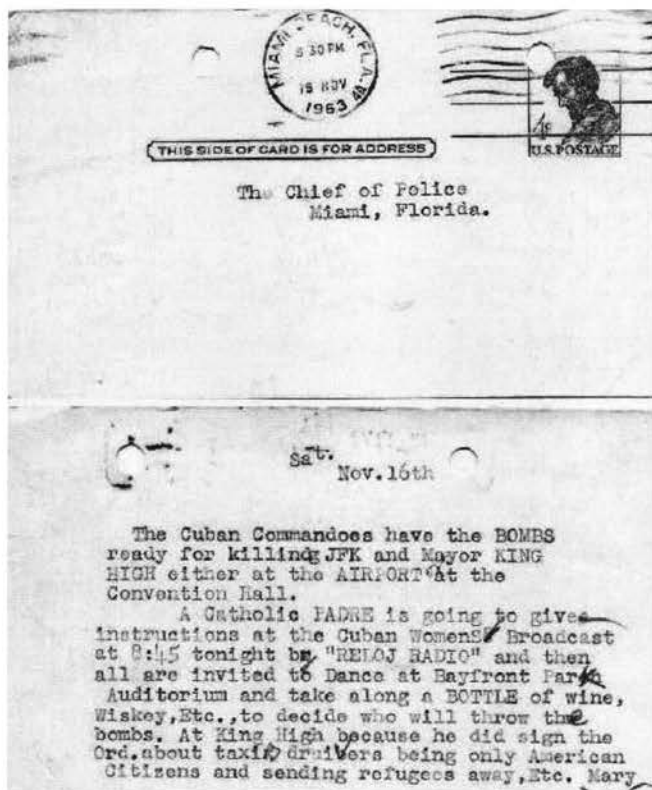

Greetings from Miami: An example, received by the Miami Police Department, of the kinds of threats being made against JFK in the Fall of 1963.

Somerset: "Boy if that Kennedy gets shot, we have to know where we are at. Because you know that will be a real shake."

Milteer: (An investigation) would leave no stone unturned there, no way. They will pick up somebody within hours afterward ... to throw the public off."

Somerset: "Oh, somebody is going to go to jail if he gets killed."

Milteer: "Just like Bruno Hauptmann in the Lindbergh case, you know."

Somerset then asked when such an assassination would take place, to which Milteer replied:

"It's in the works ... there ain't any

countdown to it. We have just got to be sitting on go. Countdown, they can move in on you, and on go they can't. Countdown is alright for a slow, prepared operation. But in an emergency situation, you have got to be sitting on go."

Captain Charles J. Sapp, of the Miami Police Intelligence Bureau, was concerned enough with Milteer's remark about the President's assassination being "in the works" to notify both the FBI and the Secret Service of the threat. Miami Police provided both agencies with copies of the taped conversation two weeks before the assassination. Despite the fact that the Miami threat was perceived as significant enough to cancel the Miami motorcade, both the FBI and the Secret Service failed to pass the information on to those responsible for the President's Dallas trip. Five years after Kennedy's murder, Milteer would express specific knowledge of murder plots against the Rev. Martin Luther King Jr. and Attorney General Robert Kennedy.

Urgent FBI Message Unheeded

On November 14, 1963, the FBI interviewed a man in Piedras Negras, Mexico, who claimed to have prior knowledge of a plot to kill JFK. He had been jailed for stealing three cars on September 30. The man, who claimed to be a member of the Ku Klux Klan, ascertained through his travels around the country that "a militant group of the National States' Rights Party was planning to assassinate the President and other high-level officials. He stated that he does not believe this is planned for the near future, but he believes that the attempt will be made."

The report added that the FBI believed him to be attempting to make some sort of deal in order to avoid prosecution for the car theft charge. Incredibly, they concluded that there was no information developed that would indicate any danger to the President in the near future or during his trip to Dallas.

In the early morning of November 17, 1963, William Walter, a security clerk in the FBI's New Orleans office, received a teletype from FBI headquarters warning of a

possible assassination attempt on Kennedy during his coming trip to Dallas on November 22nd. Walter said he was alone when he received the teletype marked "URGENT" and signed, "DIRECTOR." Following is a copy of that teletype:

URGENT 1:45 AM EST 11-17-63 HLF 1PAGE TO ALL SACS FROM DIRECTOR THREAT TO ASSASSINATE PRESIDENT KENNEDY IN DALLAS TEXAS NOVEMBER TWENTY TWO DASH TWENTY THREE NINETEEN SIXTY THREE. MISC INFORMATION CONCERNING: BUREAU HAS DETERMINED THAT A MILITANT REVOLUTIONARY GROUP MAY ATTEMPT TO ASSASSINATE PRESIDENT KENNEDY ON HIS PROPOSED TRIP TO DALLAS TEXAS NOVEMBER TWENTY-TWO DASH TWENTY-THREE NINETEEN SIXTY THREE. ALL RECEIVING OFFICES SHOULD IMMEDIATELY CONTACT ALL CIS; PCIS LOGICAL RACIAL AND HATE GROUP INFORMANTS AND DETERMINE IF ANY BASIS FOR

THREAT. BUREAU SHOULD BE KEPT ADVISED OF ALL DEVELOPMENTS BY TELETYPE. SUBMIT FD THREE ZERO TWOS AND LHM OTHER OFFICES HAVE BEEN ADVISED END AND ACK PLS.

Kennedy Visits Miami

Kennedy visited Miami as scheduled on November 18, but as a result of the recorded information provided by the Miami Police, and their fear of trouble from anti-Castro exiles, his planned motorcade through that city was cancelled and he was flown in to a scheduled speech by helicopter. The Miami police had received word of a threat by a "mobile, unidentified gunman with a high-powered rifle fitted with a scope." In addition, an anonymous typed postcard, dated 11/16/63, sent to the Chief of Police said the "Cuban Commandos have the bombs ready for killing JFK," and that they'd use them either "at the airport or the convention hall." In addition, the Secret Service received an "organized crime" threat pertaining to the same (11/18) trip.

Tampa Police reported they had received a threat from someone they described as a "white male, age 20, slender in build." A November 8 memo from the Secret Service indicated the original threat had been made in October, and that "subject stated he will use a gun, and if he couldn't get closer he would find some other way." Chief of Police, J.M. Mullins, said three people had made threats against the President, and although one was still in jail at the time of the President's visit, he did not know if the other two had followed the caravan to Dallas.

The Dallas papers announced that the motorcade route most likely would "move west on Main Street through the downtown area." However, the Chief of the Secret Service, Forrest Sorrels, made a slight change in the route: a right hand turn which would put the motorcade north on Houston Street, and a left-hand turn onto Elm Street. The purpose of the change was to obtain access to Stemmons Freeway. The route change was communicated to both Dallas papers, which published the amended route on Tuesday, November 19. After the change, the route was set to pass by the Texas School Book Depository, where Lee Harvey Oswald was working that day.

Word in the Underworld

In the early morning hours of November 20, 1963, a drug addict and prostitute named Rose Cheramie was found lying on the side of the road near Eunice, Louisiana. She had been thrown from a moving car. Battered and bruised and in a state of near hysteria, she was transported to Louisiana State Hospital in Jackson. She appeared to be under the influence of some drug. State Police Lieutenant, Francis Fruge, investigating the incident, asked her what had happened. She told him she had been traveling from Florida to Dallas with two Latin men. When he asked her what they were going to do in Dallas, she replied, "pick up some money, pick up my baby and kill Kennedy."

At the State Hospital, Cheramie repeated her claim to the doctors several times, saying that the President would be murdered in two days. She claimed to have received her information from "word in the underworld." Due to her emotional state at the time, she was thought to be in a drug-induced delirium and her story was not believed. Ironically, Lieutenant Fruge had been assigned to work the protective detail at the infamous Jung Hotel meeting in New Orleans, about five

or six days earlier, where over a hundred of the highest leaders of the radical right had held a secretive meeting.

The Richard Giesbrecht Incident

The "Winnipeg Airport Incident," or the "Richard Giesbrecht Incident," is a fascinating account of a meeting that took place in Winnipeg, Manitoba, Canada, on February 13, 1964, at the Horizon Room airport lounge. A person named Richard Giesbrecht, a "Canadian businessman waiting to meet a client," overheard a conversation among three individuals discussing what he believed to be the pending financial payoff for the perpetrators of the assassination of President John F. Kennedy, which had occurred the previous Fall.

I believe that a Spring 1964 "speaking tour through southern Canada," which started from Los Angeles late in January of 1964, involving Rev. Gerald L. K. Smith, Eric D. Butler, who belonged to the World Anti-Communist League, and Patrick J. Walsh, former Canadian correspondent for The Liberty Lobby, in all likelihood produced the persons overheard at the Winnipeg Airport meeting. (Epstein and Forster, *Report on The John Birch Society*) Dr. Revilo P. Oliver inadvertently confirmed that my identification in 1997 of Walsh and Butler as the actual persons participating in this Canadian speaking tour was accurate. You can hear this tape-recorded speech from the April 1964 Congress of Freedom meeting, which specifically mentions Butler and Walsh being picketed in Moosejaw, Saskatchewan and other Canadian cities at Oliver's website. (<http://www.revilo-oliver.com/>)

The only clues to the possible identity of those at the Winnipeg meeting involved Giesbrecht's descriptions of physical characteristics and a few snippets of the animated conversation he was able to overhear. Important highlights of that conversation are as follows:

1) A partial Ukrainian name, overheard as "Romeniuk," most likely referred to Andrij Melnyk a Vonsiatsky cohort, of the Organization of Ukrainian Nationalists, the Melnyk Group. His full name was pronounced for me as "Aahnd Row

Men-yek" in heavily-accented English by his niece from Long Island.

2) The nickname "Annie" is almost 100% likely a reference to Count Anastase "Annie" Vonsiatsky, referenced in *The Russian Fascists* by John J. Stephan. His physical description closely matches one of the participants right down to height,

Kennedy was killed by an international cabal of right-wing extremists, with links to some of the most fascist former Nazis and Nazi sympathizers ever assembled in the history of "mancruel."

weight, his bald pate, hearing aids, scars on the back of his neck, razor burns on his scalp, freckles on his hands, his Ukrainian accent, and his nickname "Annie," as disclosed by Charles Higham in *American Fascist*.

3) "Mercury" is a reference to the *American Mercury* magazine, which was published in Wichita, Kansas, by Gerald Winrod of Defenders of the Christian Faith, Inc., which moved (in the 1960s) to 250 East 57th Street, New York, within a stone's throw of Wickliffe Draper's penthouse address at 322 West 57th Street after being purchased by a Carto organization.

4) "Shipments from Newport" is most likely a reference to the Newport Beach

publications and shipping depot of the John Birch Society, formerly run by Willard Voit.

5) The reference to "a U.S. based textile operations' name containing a cloth or fabric reference" is definitely to the Draper Company, which was acquired via a white knight bailout by Rockwell-Standard in 1967 for over \$100,000,000.00.

6) "Wichita, Kansas" was most likely the location of the actual payoff meetings, probably related to either The Constitution Party meetings or The Congress of Freedom meetings held there, or perhaps even the Erich Ludendorff Society, whose headquarters were also in Wichita.

7) "Isaacs or Isaac's" was probably Isaac's Detective Agency, from *The Yahoos*, by Mike Newberry, which describes the House Un-American Activities Committee (HUAC), the Draper Committees, Wickliffe Draper, Gerald L. K. Smith and friends. John Newman also references Isaac's Detective Agency in *Oswald and the CIA*.

8) "Hochman, Hauptmann, or Hoffman or Houghton" may refer to either Troy Houghton of The Minutemen, Don Alderman, a/k/a Hal Houghton, or to Dr. Jerzy Hauptmann of the extreme right-wing. As of this writing, I am torn between Troy Houghton and Hal Houghton.

9) "The Townhouse Motel or Hotel" was the location of the annual convention of The Constitution Party of the USA in 1965 and 1966. Bert Ellis, Wickliffe Vennard and Russell Maguire, of the Connecticut-based Thompson Submachine Gun Company, were members of this party during that time period. George Lincoln Rockwell of the American Nazi Party worked for Russell Maguire at the *American Mercury*. (William F. Buckley, Jr., referenced by Richard Condon in *The Manchurian Candidate*, edited and wrote for that magazine in the early 1950s, but it is not conclusive as to what role, if any, he played in the JFK conundrum.)

If my interpretation of the identities of the persons, places and things discussed at the Winnipeg meeting is correct, Kennedy was killed by an international cabal of right-wing extremists, with links to some of the most fascist former Nazis and Nazi sympathizers ever assembled in the history of "mancruel."

I believe the planning, financing and direction of the JFK assassination was headed by HUAC's renowned Nazi sympathizer, Reverend Gerald L. K. Smith, of "Christ of the Ozarks" near Eureka Springs, Arkansas, who is the founder of the Christian Nationalist Crusade and publisher of the anti-Semitic, racist publication, *The Cross and The Flag*. Smith named his publication after one of General Douglas MacArthur's favorite sayings: "The Two greatest symbols in this country are the Cross and the Flag." The assassination plan was known to General Douglas A. MacArthur and Major Gen. Charles A. Willoughby, and was financed by Wickliffe P. Draper, sponsor of the racist Draper Committees within HUAC, and founder of The Pioneer Fund. (3)

I suggest the person identified by Giesbrecht as speaking with an Eastern European accent, with a pock-marked neck and reddish skin and hair, was Count Anastase Andreivitch Vonsiatsky (who died in

1965), world vojhd, or Führer, of the Russian Fascist Organization, the headquarters of which was located in Harbin, Manchuria, China since the 1930s. The Anglo-speaking persons involved in the Giesbrecht Incident were all dedicated current or former Nazis or neo-Nazis masquerading as professional anti-Communists. Vonsiatsky is featured in *The Russian Fascists*, by John J. Stephan.

I suggest two of the individuals at the meeting in Winnipeg were neo-Nazis formerly associated with the privately run anti-Semitic front, the Canadian Intelligence Service, and individuals who formerly belonged to the Liberty Lobby, and who may have written for the *American Mercury* in Wichita, Kansas, and possibly an Australian anti-Semite, who was a longtime associate of Dr. Fred Schwarz and his Christian Anti-Communist Crusade. All of these Nazis had direct ties to Wickcliffe P. Draper, and later belonged to the North American Regional World Anti-Communist League (NARWACL).

I believe the contributions to the JFK assassination and/or cover-up, and the contacts from active or inactive military intelligence, were coordinated by Maj. Gen. Charles A. Willoughby, who died in 1972 (Army, relieved of duty by President Harry S. Truman along with Douglas A. MacArthur), Robert J. Morris, who died in 1996 (retired Naval Intelligence), and James J. Angleton, who died in the mid-1980s (active in the Central Intelligence Agency, later fired by William Colby). All three of these military intelligence specialists shared the unique predilection of being involved with Soviet counterintelligence operations, and must have exchanged notes and discussions frequently as a matter of protocol. Their anti-Soviet, master race and anti-Semitic attitudes qualified them as more pro-Fascist than pro-Democratic. All three were in charge of Soviet counter-espionage in America for at least a decade as part of the American Security Council, Naval Intelligence, the CIA or Army Intelligence.

This implies that at one time or another in our nation's history, the entire apparatus of our Soviet counter-intelligence operations was completely subverted and dominated by outright Fascists or Nazi sympathizers. Think about it. Who is better suited to run complex anti-Soviet operations than a dedicated bunch of Nazis? What a concept! To think the U.S. actually invited many former Nazis into the country to help with the missile programs and anti-Soviet spying operations via Operation Paperclip, which was a prime example of how to relinquish control of your government to alien and seditious forces. •

©2003 All Rights Reserved. John McLoughlin has been researching the assassination of John F. Kennedy in earnest since 1990. He is the author of a work in progress tentatively entitled *JFK: The Final Solution*, highlights of which can be read at <http://www.21stCenturyInc.com/JFKArticles/JFKFinalSolution.htm>. John welcomes contact by interested parties or publishers at jfkinfo@cox.net. Thanks to Gil Jesus for his survey of right wing assassination plots.

Endnotes

(1) William W. Turner confided in me that he was one of the co-authors for *The Realist* article, but asked that his name be removed from the article at the last minute due to editorial and philosophical differences between himself and Mae Brussell regarding citations and sources. Bill Turner's

landmark 1970 work *Power on the Right* devoted an entire chapter to the American Security Council and, particularly, Robert J. Morris. Morris was later joined on the ASC by James J. Angleton, Charles A. Willoughby and Ray S. Cline.

(2) At Walter Reed, Dinkin was given therapy to help him deal with his "schizo-assassination prognostication syndrome." He was told that if his condition did not improve, he would undergo electric shock treatment, whereupon his condition dramatically "improved." He was released on a medical discharge. During the trial of Clay Shaw in New Orleans, Garrison found out that Dinkin's duty had been to decipher telegraphic traffic originating with the French OAS, which was extremely close to factions of the CIA at the time. One might surmise that Dinkin caught his unfortunate "disease" while dealing with communications between the two venerable organizations. (http://pages.prodigy.net/benede/_import/pages.prodigy.net/benede/index4.html)

(3) The Pioneer Fund continues to fund research in behavioral genetics and psychometrics (IQ studies). For example, Dr. Robert Gordon at Johns Hopkins, in research funded by The Pioneer Fund, has "demonstrated that social outcomes such as single parenthood, HIV infection, poverty, and belief in conspiracy rumors are also predicted by lower IQ." (<http://www.pioneerfund.org/>).

References

- Bellant, Russ, *Old Nazis, The New Right and The Republican Party*, 1989.
- Brussell, Mae, "The Nazi Connection to the JFK Assassination," Larry Flynt publication, *The Rebel*, Nov. 22, 1983.
- Brussell, Mae, "Assassinations are Not Mutants," *Paranoia*, Issue 16, p. 47, 1997.
- Condon, Richard, *The Manchurian Candidate*, 1958.
- Forster, Arnold and Epstein, Benjamin R., *Danger on the Right*, 1964.
- "Joseph Milteer: Miami Prophet, or Quitman Crackpot?" (<http://mcadams.posc.mu.edu/milteer.htm>)
- Russell, Dick, *The Man Who Knew Too Much*, 1992.
- Scott, Peter Dale, *Assassinations Dallas and Beyond*, 1976.
- Stephan, John J., *The Russian Fascists*, 1979.
- Turner, William W., *Power on the Right*, 1970.
- Whitney, Peter, "The Winnipeg Airport Incident," a series of articles in *The Third Decade*, (now *The Fourth Decade*), State University New York, Fredonia, New York, 14063.



The Ascendancy of the Scientific Dictatorship

Illuminating
the Origins of
Darwinism

By Phillip Darrell Collins

As antiquity gave way to modern history, the religious power structure shifted to an autocracy of the knowable, or a “scientific dictatorship.” Subtly and swiftly, the ruling class seized control of science and used it as an “epistemological weapon” against the masses. This article will show that the history and background of this “scientific dictatorship” is a conspiracy, created and micro-managed by the historical tide of Darwinism, which has its foundations in Freemasonry.

The Epistemological Cartel

In *The Architecture of Modern Political Power*, Daniel Pouzner outlines the tactics employed by the elite to maintain their dominance. Among one of them is: “Ostensible control over the knowable, by marketing institutionally accredited science as the only path to true understanding” (Pouzner 75). Thus, the ruling class endeavors to discourage independent reason, while exercising illusory power over human knowledge. This tactic of control through knowledge suppression is reiterated in the anonymously authored document, *Silent Weapons for Quiet Wars*: (1)

Energy is recognized as the key to all activity on earth. Natural science is the study of the sources and control of natural energy, and social science, theoretically expressed as economics, is the study of the sources and control of social energy. Both are bookkeeping systems. Mathematics is the primary energy science. And the bookkeeper can be king if the public can be kept ignorant of the methodology of the bookkeeping. All science is merely a means

to an end. The means is knowledge. The end is control (reprint in Keith, *Secret and Suppressed*, 203).

The word “science” is derived from the Latin word *scientia*, which means “knowing.” Epistemology is the study of the nature and origin of knowledge. Therefore, this elite monopoly of the knowable, which is enforced through institutional science, could be characterized as an “epistemological cartel.” The ruling class has bribed the “bookkeepers” (i.e., natural and social scientists). Meanwhile, the masses practically deify the “bookkeepers” of the elite, and remain “ignorant of the methodology of the bookkeeping.” The unknown author of *Silent Weapons for Quiet Wars* provides an eloquently simple summation: “The means is knowledge. The end is control. Beyond this remains only one issue: Who will be the beneficiary?” (Keith, *Secret and Suppressed*, 203)

In *Brave New World Revisited*, Aldous Huxley succinctly defined this epistemological cartel:

The older dictators fell because they could never supply their subjects with enough bread, enough circuses, enough miracles, and mysteries. Under a scientific dictatorship, education will really work ... most men and women will grow up to love their servitude and will never dream of revolution. There seems to be no good reason why a thoroughly scientific dictatorship should ever be overthrown (Huxley 116).

This is the ultimate objective of the elite, an oligarchy legitimized by arbitrarily anointed expositors of “knowledge” or, in Huxley’s own words, a “scientific dictatorship.” How did the scientific dictatorship of the

20th Century begin? In earlier centuries, the ruling class controlled the masses through mystical belief systems, particularly Sun worship. Yet, this would all change. In *Saucers of the Illuminati*, Jim Keith documents the shift from a theocracy of the Sun to a theocracy of science, where priests and rituals were soon supplanted by a new breed of “bookkeepers” and a new “methodology of bookkeeping.” Keith elaborates:

As the Sun/Moon cult lost some of its popularity, “scientists” were quick to take up some of the slack. According to their propaganda, the physical laws of the universe were the ultimate causative factors, and naturally, those physical laws were only fathomable by the scientific (Illuminati) elite (Keith, *Saucers of the Illuminati* 78-79).

It must be understood that this new institution of knowing is a form of mysticism like its religious precursors. Contemporary science is predicated upon empiricism, the idea that all knowledge is derived exclusively through the senses. Yet, an exclusively empirical approach relegates cause to the realm of metaphysical fantasy. This holds enormous ramifications for science. Do we really know what causes anything? Although temporal succession and spatial proximity are self-evident, causal connection is not. Affirmation of causal relationships is impossible in science. What is perceived as *A* causing *B* could be merely circumstantial juxtaposition. Given the absence of known cause, all of a scientist’s findings must be taken upon faith. This is all one can deduce while working under the paradigm of radical empiricism. Thus, the elite merely exchanged one form of mysticism for another.

Returning to Pouzzner’s previous statement, “ostensible control over the knowable” is achieved through the promulgation of “institutionally accredited science” (Pouzzner 75). Now, the elite had to meet two requirements to insure their epistemological dominance: a science specifically designed for their needs and an institution to accredit and disseminate it.

The British Royal Society

The new secular church and clergy of the elite originated within the walls of the British Royal Society. The creators of the Royal Society were also members of the

Masonic Lodge. According to Baigent, Leigh, and Lincoln in *Holy Blood, Holy Grail*:

Virtually all the Royal Society’s founding members were Freemasons. One could reasonably argue that the Royal Society itself, at least in its inception, was a Masonic institution—derived, through Andrea’s Christian Unions, from the “invisible Rosicrucian brotherhood” (Baigent 144).

Jim Keith makes it clear that the Masonic Lodge “has been alleged to be a conduit for the intentions of a number of elitist interests” (Keith, *Casebook on Alternative Three* 20). In service to the elite, the Royal Society Freemasons would re-sculpt epistemological notions and disseminate propaganda. Jim Keith provides a brief summation of the Royal Society’s role in years to come: “The British Royal Society of the late 17th Century was the forerunner of much of the media manipulation that was to follow” (Keith, *Saucers of the Illuminati* 79).

Before the advent of the British Royal Society, science (i.e. the study of natural phenomena) and theology (i.e., the study of God) were inseparable. The two were not separate repositories of knowledge, but natural correlatives. In *Confession of Nature*, Gottfried Wilhelm Leibniz established the centrality of God to science. According to Leibniz, the proximate



Recognizing the odd synchronicity between the communist concept of class war and the Darwinian principle of natural selection, Karl Marx sent Darwin a copy of *Das Kapital* in 1873.

origins of “magnitude, figure, and motion,” which constitute the “primary qualities” of corporeal bodies, “cannot be found in the essence of the body” (de Hoyos). Linda de Hoyos reveals the point at which science finds a dilemma:

The problem arises when the scientist asks why the body fills this space and not another; for example, why it should be three feet long rather than two, or square rather than round. This cannot be explained by the nature of the bodies

themselves, since the matter is indeterminate as to any definite figure, whether square or round. For the scientist who refuses to resort to an incorporeal cause, there can be only two answers. Either the body has been this way since eternity, or it has been made square by the impact of another body. "Eternity" is no answer, since the body could have been round for eternity also. If the answer is "the impact of another body," there remains the question of why it should have had any determinate figure before such motion acted upon it. This question can then be asked again and again, backwards to infinity. Therefore, it appears that the reason for a certain figure

Darwin was the crucible for Hitler's notions of biology, worship, force, and struggle, and of his rejection of moral causality in history.

and magnitude in bodies can never be found in the nature of these bodies themselves.

The same can be established for the body's cohesion and firmness, which left Leibniz with the following conclusion:

Since we have demonstrated that bodies cannot have a determinate figure, quantity, or motion, without an incorporeal being [God], it readily becomes apparent that this incorporeal being is one for all, because of the harmony of things among themselves, especially since bodies are moved not individually by this incorporeal being but by each other. But no reason can be given why this incorporeal being chooses one magnitude, figure, and motion rather than another, unless he is intelligent and wise with regard to the beauty of things and powerful with regard to their obedience to their command. Therefore such an incorporeal being be a mind ruling the whole world, that is, God. (de Hoyos)

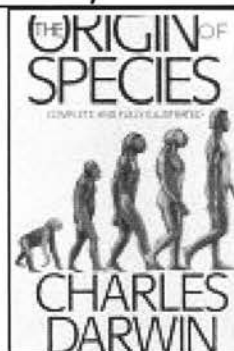

Of course, this conclusion was antithetical to the doctrine of the scientific dictatorship, which contended that "the physical laws of the universe were the ultimate causative factors" (Keith, *Saucers of the Illuminati* 78-79). Metaphysical naturalism (i.e., nature is God) had to be enthroned. Meanwhile, God's presence in the corridors of science had to be expunged. To achieve this, the Royal Society created a division between science and theology, thus insuring the primacy of matter in the halls of scientific inquiry (Tarpley 1996).

Evolution: The Occult Doctrine of Becoming

With the British Royal Society acting as their headquarters of propaganda, the elite had created an institution to provide credibility for their specially designed "science." Now, they needed to introduce the "science." The founding members of the Royal Society were all

Freemasons; thus, whatever "science" these men would design would be derivative of Masonic doctrine. In *The Meaning of Masonry*, W.L. Wilmhurst reveals the world view underpinning the new Masonic "science":

This—the *evolution* [emphasis added] of man into superman—was always the purpose of the ancient Mysteries, and the real purpose of modern Masonry is not the social and charitable purposes to which so much attention is paid, but the expediting of the spiritual evolution of those who aspire to perfect their own nature and transform it into a more god-like quality. And this is a definite science, a

royal art, which it is possible for each of us to put into practice; whilst to join the Craft for any other purpose than to study and pursue this science is to misunderstand its meaning (Wilmhurst 47).

Later in the book, Wilmhurst reiterates this theme:

Man who has sprung from earth and developed through the lower kingdoms of nature to his present rational state, has yet to complete his *evolution* [emphasis added] by becoming a god-like being and unifying his consciousness with the Omniscient—to promote that which is and always has been the sole aim and purpose of all Initiation (Wilmhurst 94).

With God's exile from science, man's position as *imago viva Dei* (created in the image of the Creator) became obsolete. Freemasonry could now introduce its occult doctrine of "becoming," the belief in man's gradual evolution towards apotheosis. According to *Mackey's Encyclopedia of Freemasonry*, Erasmus Darwin, grandfather of Charles Darwin, was the first to promulgate the concept of evolution:

Dr. Erasmus Darwin (1731-1802) was the first man in England to suggest those ideas which later were to be embodied in the Darwinian Theory by his grandson, Charles Darwin (1809-1882), who wrote in 1859 *Origin of Species* (Daniel, *Scarlet and the Beast* 34).

Erasmus was the founder of the Lunar Society. According to Ian Taylor, the Lunar Society was active from about 1764 to 1800, and its prominent influence "continued long afterwards under the banner of The Royal Society." The group's name owed itself to the fact that members met monthly at the time of the full moon. The membership of this group boasted such luminaries as John Wilkinson (who made cannons), James Watt (who owed his notoriety to the steam engine), Matthew Boulton (a manufacturer), Joseph Priestly (a chemist), Josiah Wedgewood (who founded the famous pottery business), and Benjamin Franklin. It is with the Lunar Society that one begins to identify Erasmus' ties to Freemasonry. (Taylor 55)

Interestingly enough, in an article by Lord Richie-Calder, Lunar Society members were assigned the very esoteric appellation of "merchants of light." This was precisely the same description used for the hypothetical society presented in Sir Francis Bacon's *New Atlantis* (Taylor 55). Conspiracy researcher, Nesta H. Webster, in her examination of J.G. Findel's *History of Freemasonry*, made the following observation: "Findel frankly admits that *New Atlantis* contained unmistakable allusions to Freemasonry and that Bacon contributed to its final transformation." (Webster 120) Taylor clarifies:

Webster pointed out that one of the earliest and most eminent precursors of Freemasonry is said to have been Francis Bacon, who is also recognized to have been a Rosicrucian; the Rosicrucian and Freemason orders were closely allied and may have had a common source. (Taylor 445)

Still, these are tenuous ties at best. Are there any sources that firmly establish a Darwinian/Freemasonic connection? *Mackey's Encyclopedia of Freemasonry* conclusively confirms a link:

Before coming to Derby in 1788, Dr. [Erasmus] Darwin had been made a Mason in the famous Time Immemorial Lodge of Cannongate Kilwinning, No. 2, of Scotland. Sir Francis Darwin, one of the Doctor's sons, was made a Mason in Tyrian Lodge, No. 253, at Derby, in 1807 or 1808. His son Reginald was made a Mason in Tyrian Lodge in 1804. The name of Charles Darwin does not appear on the rolls of the Lodge but it is very possible that he, like Francis, was a Mason (Daniel 34).

In 1794, Erasmus Darwin wrote a book entitled *Zoonomia*, which delineated his theory of evolution. Being a Freemason, there is little doubt that Erasmus cribbed liberally from the Lodge's occult doctrine of "becoming." Before Freemason Erasmus Darwin penned his precursory notions of progressive biological development, Freemason John Locke had extrapolated the Hindu doctrine of reincarnation into the realm of science, and formulated a theory of evolution. The British East India Company had imported the Hindu belief in reincarnation to England, where it would be adopted by the British Royal Society. A prominent member of the Royal Society, John Locke studied reincarnation extensively and, extrapolating on occult doctrine, developed his own evolutionary ideas. In fact, Locke's theory of evolution received the support of the male members of

Northern Voice Bookstore

We have hundreds of
books and videos on:

NWO
CONSPIRACY
PRIVACY
FREEDOM
SELF-DEFENSE
ALTERNATIVE SCIENCE
POLITICS

Try us, you'll like us. Send \$2 for
catalog to: Northern Voice Bookstore,
P.O. Box 281-C, Wildwood, PA 15091.

Darwin's family (Daniel 33-34). Two centuries later, his occult concept of "becoming" was transmitted to Charles Darwin, and *On the Origin of Species* was born.

The Darwin Project

In the article "Toward a New Science of Life," *EIR* journalist, Jonathan Tennenbaum, writes:

Now, it is easy to show that Darwinism, one of the pillars of modern biology, is nothing but a kind of cult, a cult religion. I am not exaggerating. It has no scientific validity whatsoever. Darwin's so-called theory of evolution is based on absurdly irrational propositions, which did not come from scientific observations, but were artificially introduced from the outside, for political-ideological reasons (Tennenbaum).

Given Darwinism's roots in occult Freemasonry, and Freemasonry's expedient promotion of an emergent species of supermen—the elite—this is a fairly accurate assessment. Charles Darwin acted as the elite's apostle, preaching the new secular gospel of evolution. Darwinism could be considered a Freemasonic project, the culmination of a publicity campaign conducted by the Lodge. Evidence for this contention can be found in the controversial *Protocols of the Wise Men of Zion*. Although an examination of the *Protocols* and a critique of their authenticity are not the purposes of this essay, it is important to address the questions surrounding their origin. After all, the *Protocols* have been employed throughout history in numerous genocidal campaigns against the Jews. However, the authors of *Holy Blood, Holy Grail* provide evidence that the document may be Masonic in origin:

It can thus be proved conclusively that the *Protocols* did not issue from the Judaic congress at Basle in 1897. That being so, the obvious question is whence they did issue. Modern scholars have dismissed them as a total forgery, a wholly spurious document concocted by anti-Semitic interests intent on discrediting Judaism. And yet the *Protocols* themselves argue strongly against such a conclusion. They contain, for example, a number of enigmatic references—references that are clearly not Judaic. But these references are so clearly not Judaic that they cannot plausibly have been fabricated by a forger, either. No anti-Semitic forger with even a modicum of intelligence would possibly have concocted such

references in order to discredit Judaism. For no one would have believed these references to be of Judaic origin.

The text of the *Protocols* ends with a single statement: "Signed by the representatives of Zion of the 33rd Degree." Why would an anti-Semitic forger have made up such a statement? Why would he not have attempted to incriminate all Jews, rather than just a few—the few who constitute "the representatives of Zion of the 33rd Degree"? Why would he not declare that the document was signed by, say, the representatives of the international Judaic Congress? In fact, the "representatives of Zion of the 33rd Degree" would hardly seem to refer to Judaism at all, or to any "international Jewish conspiracy." If anything, it would seem to refer to something specifically Masonic. The 33rd Degree in Freemasonry is the Strict Observance—the system of Freemasonry introduced by Hund at the behest of his "unknown superiors," one of whom appears to have been Charles Radclyffe (Baigent 192-3).

Baigent, Leigh, and Lincoln conclude:

There was an original text on which the published version of the *Protocols* was based. This original text was not a forgery. On the contrary, it was authentic. But it had nothing whatever to do with Judaism or an "international Jewish conspiracy." It issued, rather, from some Masonic organization or Masonically oriented secret society that incorporated the word "Zion" (Baigent 194).

Given the Masonic language, one can discard the racist contention that the *Protocols* constitute evidence of an "international Jewish conspiracy." Nevertheless, the document holds some authenticity:

The published version of the *Protocols* is not, therefore, a totally fabricated text. It is, rather, a radically altered text. But despite the alterations, certain vestiges of the original version can be discerned... (Baigent 195).

The remnant of the original text strongly suggests Masonic origins. Having established the Masonic authorship of the *Protocols*, one may return to the issue at hand: Freemasonic involvement in the promotion of Darwinism. Consider the following excerpt from the *Protocols*, which reads distinctly like a mission statement:

For them [the masses or cattle] let that play the principal part which we have persuaded them to accept as the dictates of science (theory). It is with

this object in view that we are constantly, by means of our press, arousing a blind confidence in these theories. The intellectuals of the *goyim* [the masses or cattle] will puff themselves up with their knowledge and without any logical verification of it will put into effect all the information available from science, which our *agentur* specialists have cunningly pieced together for the purpose of educating their minds in the direction we want.

Do not suppose for a moment that these statements are empty words: think carefully of the successes we arranged for *Darwinism* [emphasis added], Marxism, and Nietzsche-ism (reprint in Cooper 274-5).

In addition to establishing the Lodge's official sanction of Darwinism, this excerpt also reveals a direct relationship between Marxism, Nietzsche-ism and evolutionary theory, which will be discussed shortly.

The grandfather of Aldous Huxley, T.H. Huxley, would act as the "official spokesman for the recluse Darwin" (White 268). Recall that, many years later, Aldous would propose a "scientific dictatorship" in *Brave New World Revisited*. Whether Aldous made this proposition on a whim, or was penning a concept that had circulated within the Huxley family for years, cannot be determined. Given the family's oligarchical tradition, the latter assertion is a definite possibility. Yet, there may be a deeper Freemasonic connection, suggesting that the concept of a "scientific dictatorship" may have originated within the Lodge.

T.H. Huxley was a Freemason and, with no apparent achievements to claim as his own, was made a Fellow of the Royal Society at the age of 26 (Daniel 34). T.H. Huxley tutored Freemason, H.G. Wells, who would later teach Huxley's two grandsons, Julian and Aldous. Both Julian and Aldous were Freemasons (Daniel 147). Given this continuity of Freemasonic tutelage within the Huxley family, it is a definite possibility that the Huxlian concept of a "scientific dictatorship" is really Masonic. With the publicity campaigns of the Royal

Society, and the avid defense of evolution propagandist, T.H. Huxley, Darwin's theory would be disseminated and popularized. The seed had taken root and, in the years to come, numerous permutations of the elite's "scientific dictatorship" would emerge.

Darwinism Dismantled

Providing a complete and comprehensive delineation of the various concepts constituting Darwinism is a daunting task. The theory itself is a dense amalgam of "-isms," thinly veiled occult concepts, philosophical doctrines, and ideologies. Again, Tennenbaum's statement that Darwinism "is based on absurdly irrational propositions, which did not come from scientific observations, but were artificially introduced from the outside, for political-ideological reasons" seems succinct and accurate. But, with what outside sources do these

John Locke's theory of evolution received the support of the male members of Darwin's family. Two centuries later, Locke's occult concept of "becoming" was transmitted to Charles Darwin, and *On the Origin of Species* was born.

"absurdly irrational propositions" find their proximate origins?

One of the many constituent world views comprising Darwinism is Hegelianism. According to philosopher, Georg Hegel, a pantheistic world spirit was directing "an ongoing developmental (evolutionary) process in nature, including humanity," which bodied itself forth as a "dialectical struggle between positive and negative entities." This conflict always resulted in a "harmonious synthesis" (Taylor 381-382). The same dialectical framework is present in Darwinism.

In *Circle of Intrigue*, occult researcher, Texe Marrs, reveals the Hegelian structure intrinsic to Darwinian evolution. The organism (thesis) comes into conflict with nature (antithesis) resulting in a newly enhanced species (synthesis), the culmination of the evolutionary process (Marrs 127). Of course, in such a world of ongoing conflict, violence and bloodshed are central to progress. Thus, Darwin's theory "gave credence to the Hegelian notion that human culture had ascended from brutal beginnings" (Taylor 386).

Yet, Darwinism's roots go deeper than Hegelianism, returning to an earlier esoteric source. In turn, Hegel's ideas originated with Fichte, who was "a Freemason, almost certainly Illuminati, and certainly promoted by the Illuminati" (Sutton, *America's Secret Establishment* 34). In fact, Hegel's dialectical logic reiterates the Masonic dictum, *Ordo Ab Chao* (Order out of chaos). It appears that the bedrock upon which Darwinism rests is Freemasonry, a channel for elitist interests.

...Fascism or Marxism, right wing or left – all these are only ideologi- cal roads that lead to Aldous Huxley's "Brave New World..."

The Rise of the Scientific Dictatorship

Darwinism shares the Hegelian framework with two other belief systems. In *The Secret Cult of the Order*, Antony Sutton states: "Both Marx and Hitler have their philosophical roots in Hegel" (Sutton 118). It is here that one arrives at the Hegelian nexus where Darwin, Marx, and Hitler intersect. Recall that Nietzsche-ism, Darwinism and Marxism were all mentioned together in the *Protocols of the Wise Men of Zion*. This was no accident. Nazism (a variant of fascism) sprung from Nietzsche-ism, and Communism sprung from Marxism. Both were based upon Hegelian principles. Moreover,

both were "scientific dictatorships" legitimized by the "science" of Darwinism. Ian Taylor elaborates:

However, Fascism or Marxism, right wing or left—all these are only ideological roads that lead to Aldous Huxley's brave new world [i.e. a "scientific dictatorship"], while the foundation for each of these roads is Darwin's theory of evolution. Fascism is aligned with biological determinism and tends to emphasize the unequal struggle by which those inherently fittest shall rule. Marxism stresses social progress by stages of revolution, while at the same time it paradoxically emphasizes peace and equality. There should be no illusions; Hitler borrowed from Marx. The result is that both Fascism and Marxism finish at the same destiny—totalitarian rule by the elite (Taylor 411).

The interest of both Hitler and Marx in Darwinian evolution is a matter of history. While he was living in London, Karl Marx attended lectures on evolutionary theory delivered by T.H. Huxley. Recognizing the odd synchronicity between the communist concept of class war and the Darwinian principle of natural selection, Marx sent Darwin a copy of *Das Kapital* in 1873. Enamored of evolution, Marx asked Darwin for permission to dedicate his next volume to him six years later.

Troubled by the fact that it would upset certain members of his family to have the name of Darwin associated with an atheistic polemic, Charles politely declined the offer. (Taylor 381)

Numerous authors have established firm connections between Darwinism and Hitler's Nazism. Darwinian, Sir Arthur Keith, documented the strong links between Hitler's racialist goals and the doctrine of evolution. In fact, in his 1947 book, *Evolution and Ethics*, Keith wrote: "The German Fuhrer, as I have consistently maintained, is an evolutionist; he has consciously sought to make the practice of Germany conform to the theory of evolution" (Keith 230). Also, in an analysis of *Mein Kampf*, contemporary author, Werner Maser, reveals that Darwin was the crucible for Hitler's "notions of

biology, worship, force, and struggle, and of his rejection of moral causality in history" (Taylor 409). Researcher, Alfred Kelly, also provides a comprehensive history of Darwinism's popularization in Germany.

Conclusion

Returning to the Hegelian nexus that binds Darwinism, Marxism and Nazism, both the fascist and communist "scientific dictatorships" were a political enactment of evolutionary theory. Marx was greatly influenced by Hegel (Taylor 381). The concept of class struggle, which paralleled Darwinian natural selection, was the result of Marx's redirection of the Hegelian dialectic into the socioeconomic realm. The proletariat (thesis) comes into conflict with the bourgeois (antithesis), resulting in a classless Utopia (synthesis). Marx, however, rejected the concept of a world spirit, and relocated the revolution's causal source within the proletariat itself.

The same Hegelian framework was evident in Hitler's genocidal Final Solution. The German people (thesis) came into conflict with the Jew (antithesis) in hopes of creating the Aryan (synthesis). In both Communism and Nazism, the results were enormous bloodbaths. This is the natural consequence of Darwinian thinking and the legacy of the "scientific dictatorship." In tangibly enacting the ideas of Darwin, both communists and fascists have murdered millions. Both of these groups find their origins in the elite (the Illuminati), who are still pursuing the same objectives today. According to the Darwinian mantra of "survival of the fittest," victory will demand bloodshed. The Huxlian New World Order shall be eugenically regimented in accordance with Darwinian principles.

In *Brave New World Revisited*, Aldous Huxley forewarns, "... the 21st Century ... will be the era of World Controllers..." (Huxley 25). If the scientific dictatorship introduced by these World Controllers is anything like its precursors, humanity may stand to inherit a bloody legacy in the near future. •

Phillip Darrell Collins is the editor of *The Hidden Face of Terrorism*, a book by Paul David Collins. He can be contacted at thefaceunveiled@excite.com.

Footnotes

(1) *Silent Weapons for Quiet Wars* (dated May 1979) was claimed to have been found in a surplus IBM copy machine in 1986 by a Boeing Aircraft employee. Excerpted on p. 56.

References

- Baigent, Michael, Richard Leigh, & Henry Lincoln, *Holy Blood, Holy Grail*, Delacorte Press, New York, 1982.
- Cooper, William, *Behold a Pale Horse*, Light Technology Publishing, Sedona, Arizona 1991.
- Daniel, John, *Scarlet and the Beast: Volume II*, JKI Publishing, Tyler, Texas, 1994.

de Hoyos, Linda, "The Enlightenment's Crusade Against Reason," *The New Federalist; American Almanac*, February 8, 1993.

Huxley, Aldous, *Brave New World Revisited*, Bantam Books, New York 1958.

Keith, Arthur, *Evolution and Ethics*, Putnam, New York, 1947.

Keith, Jim, *Casebook on Alternative Three*, Illuminet Press, Lilbum, Georgia 1994.

Keith, Jim, *Saucers of the Illuminati*, Illuminet Press, Lilbum, Georgia 1999.

Keith, Jim, *Secret and Suppressed*, Feral House, Portland, Oregon 1993.

Marrs, Texe, *Circle of Intrigue*, Living Truth Publishers, Austin, Texas 1995.

Pouzzner, Daniel, *The Architecture of Modern Political Power: The New Feudalism*, <http://www.mega.nu:8080>, 2001.

Sutton, Antony, *America's Secret Establishment*, Liberty House Press, Billings, Montana 1986.

Sutton, Antony, *The Secret Cult of the Order*, Veritas Publishing Company PTY. Ltd., Bullsbrook, Western Australia 1983.

Taylor, Ian T., *In the Minds of Men: Darwin and the New World Order*, TFE Publishing, Minneapolis, MN 1999.

Tarpley, Webster, "How the Venetian System Was Transplanted Into England," *The New Federalist*, June 3, 1996.

Tennenbaum, Jonathan, "Towards a New Science of Life," *Executive Intelligence Review*, Vol. 28, Number 34, Sept. 7, 2001.

Webster, Nesta H., *Secret Societies and Subversive Movements*, 1924.

White, Carol, *The New Dark Ages Conspiracy*, The New Benjamin Franklin House, New York 1980.

Wilmhurst, W.L., *The Meaning of Masonry*, Gramercy Books, New York 1980.

BIPED

Beings for Intelligent Purpose in Evolutionary Design

The Website of Darwinian Dissent!

Learn how Intelligent Design Theory is Making a Monkey out of Darwin

Articles by Joan d'Arc, Phillip Collins and others.

Coming in Sept. 2003

www.biped.info





We All Live in a Yellow Submarine

By
Adam Gorightly

The Manson Family and the Beatles

I think it's a subconscious thing. I don't know whether they did it or not. But it's there. It's an association in the subconscious. This music is bringing on the revolution, the unorganized overthrow of the Establishment. The Beatles know in the sense that the subconscious knows. —Charles Manson

It was another ceremony around the campfire at Barker Ranch, like so many before in the high desert or at Spahn Ranch. Charlie Manson had just returned from his L.A. trip with Dennis Wilson of the Beach Boys.

All the peace and love vibes that had once been Manson's calling card were gradually dissolving and in their place paranoia was oozing in—at steadily increasing doses—warning of impending disaster just around the bend. A large part of Charlie's inspiration for this sudden mood swing could be attributed to The Beatles' White Album, which he spoke about in solemn tones around the campfire as it reflected intensely in his eyes:

Are you hep to what the Beatles are saying? They're telling it like it is. They know what's happening in the city; blackie is getting ready. They put the revolution to music ... it's 'Helter-Skelter.' Helter-Skelter is coming down. Hey, their album is getting the

young love ready, man, building up steam. Our album is going to pop the cork right out of the bottle.

Although growing steadily more paranoid about the general state of the modern world, Charlie's optimism about his recording career had been renewed by his recent trip into the city, and the release of his song "Never Learn Not To Love." Paul Watkins—in his Tate/LaBianca testimony—gave his own spin on the Manson Family mindset during this period:

Our music was going to lure Whitey's daughters to the desert, away from Haight Ashbury. Blackie would have no other means of releasing his tensions, so would turn to the white establishment. The murders were going to start in rich places like Bel Air and Beverly Hills in the summer of 1969. The super-atrocious crimes would disturb the rich piggies; the spades would scare Whitey. They'd go to the ghetto and shoot the garbage man and the

Uncle Toms. The Black Muslims would be in hiding. The whites would split up the middle, some saying, 'Look at the things you are doing to the blacks!' The whites would kill each other off. Then the Black Muslims would come in and kill the rest of them. Helter Skelter is the end of the cycle. What was on top had to go on the bottom. The karma of the whites is over and the black's karma begins. But then Revolution 9 takes over. This is described in Revelation 9.

The black man would have to clean up the mess the white had made of the world, rebuild the cities and all that. But Blackie can't do it all alone. He will have completed his karma, and he'll have to come to the 'family.' Charlie will pat his fuzzy head and kick him. Charlie will have to show him how. Meanwhile, the 'family' will have grown to 144,000 like the twelve tribes of Israel in Revelation. Charlie encourages the girls to get pregnant. And we'll have buses to collect all the children when Helter Skelter comes down, so we can save them and raise them in our hole in the desert. The bottomless Pit. That's in Revelation 9, too. Charlie's mission is to complete the karma of the world.

Throughout late '68 and early '69, Family members were spread throughout Death Valley, Topanga Canyon, Laurel Canyon, and one or more in England, allegedly with The Process. One former Manson Family associate claims that four to six members of the group lived on Laurel Canyon Boulevard in a log cabin once owned by actor Tom Mix. In Manson's famous letter to *The Hollywood Star*, he reminisced about the Tom Mix house:

We had a pool full of naked beauties and strobe lights in the living room and sex in five bedrooms and all the closets

had secret doors that go from bedroom to bedroom plus guest house, big beds, pool shacks, and mattresses in the living room, a tree house, sex all over the grounds, in the rose gardens, under the trees. Neil Diamond used to come over. Mike Love of the Beach Boys, Doris Day's son, Angela Lansbury's daughter Dee Dee, Sinatra's daughter Nancy, used to be at the beach pad.

The Yellow Submarine

Around this time, Charlie and gang moved into a house at 21019 Gresham Street in Canoga Park, less than twenty minutes from Spahn Ranch. The house, made of stucco and redwood, was painted a bright canary yellow, and soon became known in Family lore as "The Yellow Submarine." From there, Charlie said,

the Family would remain "submerged beneath the awareness of the outside world"

while working on their music. The property itself sat on an acre of ground, with four bedrooms, two baths, a big kitchen and a large front room that was used as studio for Family recording sessions. According to Charlie, in *Manson In His Own Words*, within four weeks of moving into the Yellow Submarine, it had become a "concert hall for musicians, a porno studio for kinky producers, a dope pad, a thieves' lair, a place to dismantle stolen cars and just about everything but a warehouse."

About a week or so after they moved into The Yellow Submarine, Charlie sent a squad back to Barker

Ranch to retrieve Brooks, Juanita, and Gypsy, the remaining Family members who had stayed behind to look after things. Around this time, two new girls joined the fold: Crazy Patty, a petite hippie chick from Canoga Park, and seventeen year old Barbara Hoyt, a buxom brunette, who would

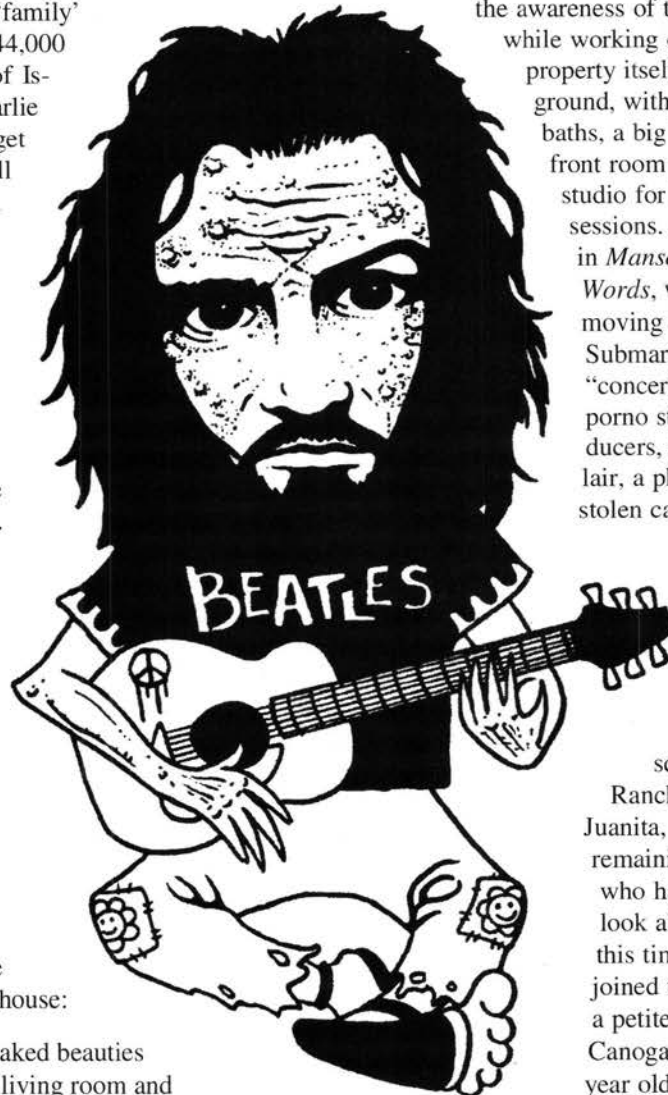

soon change her name to Bo Rosenberg.

The legendary "Death Mockup Party" was a prime example of the mounting weirdness that began to take hold during the Gresham Street period. They were all sitting around stoned in the middle of the living room one night, apparently postulating their own deaths, when Charlie, strategically positioned in the midst of the gathering, said, "Die," so they all laid down and pretended to die, goodbye. Bo started screaming. Manson moved his fingers about in strange reptilian patterns, talking about the confusion in the air and how groovy it all was.

Meanwhile, Brooks Posten had gone into a deep trance, and Charlie commanded him to die. Posten died in his own mind and stayed in this "Death Trance" for a total of five days. As he lay wasting away on the living room couch, the girls would periodically clean up after his natural bodily functions. On the fifth day of Brook's death, Charlie commanded that his very own ceremonial vest be placed beneath the ego-dead disciple as a sort of symbolic diaper, and with this one humble messianic act, Charlie was able to resurrect Brooks back to the world of the living, just like Jesus in the Bible awoke Lazarus. Charlie looked down upon Brooks and said, "I command you to live again!" With Charlie's commandment, Brooks' eyes opened, and slowly and painfully he rose to his feet. Saith Charlie then: "Now I accept you."

Charlie's Music Career

Shortly after moving into the Gresham Street pad, the Family was paid a visit by Dennis Wilson and Greg Jakobson, who—after hearing Charlie and the gang play a few tunes—were enthused about the new "desert music." Because of this, Wilson, Jakobson and Terry Melcher scheduled a couple of recording sessions, the first one at a studio in Westwood Village.

When Charlie went to the studio for the first session, he brought the whole mob with him—about fifteen all told—invading the place like some sort of hippie free-for-all. Right away the guy who ran the studio started telling Charlie and his gang what they could and couldn't do; where to sit, where to stand, which way to face, even how to hold the microphone. At first, they complied with the studio manager's requests, but when it came time for Manson to lay down his vocals, the girls wanted to be looking at him when they sang background. As the girls started moving away from the place where they'd been positioned, the studio manager came unglued.

In the end, the scene was a repeat performance of what went down at previous recording sessions, as Charlie felt the studio wouldn't let him perform his music the way he wanted to, free from the restraints and deadlines of studio managers and record producers pushing their trip on him. Nevertheless, Manson man-

aged to record about a dozen songs, two of which were spontaneously composed. It was at this session that Manson really freaked-out Terry Melcher with a little spontaneous ditty of guitar vamp and scat-singing of apparently non-sense syllables "digh-tu-dai, deigh-du-doi, di-tew-deigh" which gradually became clearer until "di-tew-deigh, die-tew-dai," became "die today, die today, die today."

Much has been made about Charlie's aborted music career. Some suggest his failure to "hit the big time" was the main motive behind the Tate murders; that Charlie felt spurned by Terry Melcher, and in retaliation sent his shock troops to 10050 Cielo Drive to even the score. Manson scoffs at such accusations as pure rubbish, insisting that his musical career was never of great importance to him.

The Hollywood S&M Scene

Charlie and the girls soon found themselves invited to private parties in Beverly Hills, Malibu and other exclusive areas. Until getting mixed up in the Hollywood set, they had not been involved with kinky orgies that featured performances a la whips and chains, but they were drawn into it by this depraved Hollywood crowd, besot with loose morals and hard drug habits. It's interesting to note that whenever Charlie talks about this S&M scene, there is a certain amount of bitterness in his tone, indicating that something ugly might have gone down during this period. The Manson Family-Hollywood connections ran deep, and for many years Charlie was reticent to finger the rich and famous that had intersected his star-crossed path.

Manson decided to lift the lid a little when he responded to a request from a gossip tabloid in the mid-70s, *The Hollywood Star*. Among the big names that Charlie named were Elvis, Neil Diamond, various members of the Beach Boys, Nancy Sinatra, Jane Fonda, Yul Brynner, Peter Sellers and Peter Falk. When Frank Sinatra caught wind that the publisher of *The Hollywood Star*—Bill Dakota—was calling his daughter Nancy to pump her for information regarding alleged Manson sex orgies, the "Chairman of the Board" threatened to send out some of his boys to break Dakota's knee caps if the publisher didn't cease and desist with his inquiries.

According to Terry Melcher, in *Doris Day: Her Own Story*, one persistent rumor surrounding the Tate-LaBianca murders was that Jay Sebring lured some of Charlie's girls into one of the sado-porn films that he and his Hollywood friends were making, whipping and beating them before the camera, thus conceivably igniting the horrendous carnage of the Tate-LaBianca murders. It doesn't take an overwhelming leap to entertain the possibility that all of this kinky weirdness might have led to the murderous rituals that unfolded during the hot August nights of 1969.

Sammy Goes Satanic

In his autobiography, *Why Me?*, Sammy Davis, Jr. recounted a party he attended in the late 60s, which turned out to be an orgy highlighted by a simulated virgin sacrifice. To his surprise, Davis discovered that the hooded man acting as the leader of the "coven" was none other than Jay Sebring, who—as Davis puts it—had always been "a little weird." Sebring had constructed a dungeon in his basement and tried unsuccessfully to entice Davis over to view the "real antique pieces" (torture weapons) he had collected. Shortly after the party, Davis met Anton LaVey, founder of the Church of Satan, who warned him not to get involved in the Church of Satan unless he was totally serious about the commitment. Davis, while not totally serious, joined anyway, because he "wanted to have every human experience" possible.

In his Vegas nightclub act, Sammy openly flaunted one symbolic red fingernail, and wore a Church of Satan Baphomet pendant around his neck. "The chicks loved it," playboy swinger Sammy noted, a smoke dangling from his lips. At one point things started getting even too weird for Sammy-baby. "One morning after a 'coven' that wasn't quite fun and games," he recalled, "I got some nail polish remover and took off the red fingernail."

Neil Diamond Stole My Chops

Manson, never shy about name-dropping, also claims to have met and influenced many of the movers and shakers of the 60's music industry. Among those whom Manson says "stole his chops" were The Beach Boys, Neil Diamond and The Buffalo Springfield. According to Sandy Good, former Springfield member, Neil Young, was amazed at Charlie's rhythmic style of playing, and supposedly gave Manson a motorcycle. Young's song "Mansion on the Hill" from *Ragged Glory*

has long been rumored to be about his meeting with Charlie in the 60's (i.e. "Manson on the Hill"): "His words were kind but his eyes were wild, he said 'I got a load to lug but I want one more trial.'" Another Manson-influenced tune by Neil Young is "Revolution Blues." Young—who met Manson through Dennis Wilson—has been quoted as saying:

He wanted to make records. He wanted me to introduce him to Mo Ostin at Reprise. He had this kind of music that

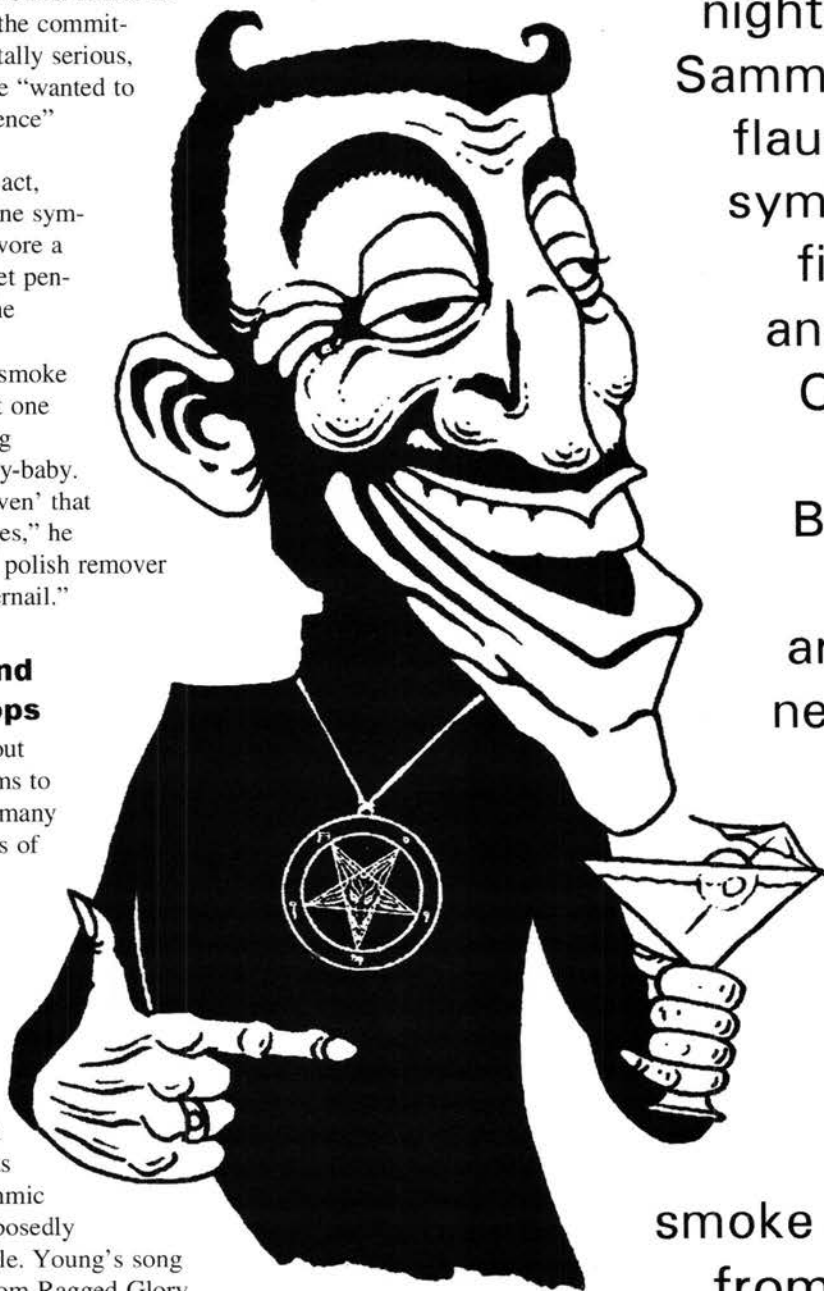

In his Vegas nightclub act, Sammy openly flaunted one symbolic red fingernail, and wore a Church of Satan Baphomet pendant around his neck. "The chicks loved it," playboy swinger Sammy noted, a smoke dangling from his lips.

nobody else was doing. He would sit down with a guitar and start playing and making up stuff, different every time, it just kept on comin' out, comin' out, comin' out. Then he would stop and you would never hear that one again. ... Musically, I thought he was very unique. I thought he really had something crazy, something great. He was like a living poet.

Operation Helter-Skelter

During the Yellow Submarine period, Manson began recruiting former prison buddies and outlaw bikers and mechanics to help him score and repair dune buggies and Harleys. From his experiences in the rough and rugged terrain of Death Valley, Manson decided that dune buggies best fit the bill for the Family's envisioned mass exodus into the desert, as they were great for outrunning the pigs, and were light enough so that two or three Family members could lift them over impassable boulders and gullies. Manson would later outfit his sacred dune buggies with huge gas tanks, giving them a thousand-mile distance capability, and even put on machine gun mounts in preparation for Revelation.

Charlie's own personal buggy was adorned with hanks of human hair, affixed to the roll-bar, donated by all the female Family members.

One of Charlie's ex-con recruits was Bill Vance (aka David Lee Hamic), who Charlie once recalled had a different name each time he met him. Vance was a hulking six-footer in his late forties, with a battered face and a nose that looked like a craggy mountain range. He had been heavyweight champion of Brushy Mountain Prison, in Tennessee, one of the roughest prisons in the U.S., for nine years, which was some kind of record. They hit it off immediately, and Charlie used this liaison to his further his own ends.

On March 23rd, 1969, Bobby Beausoleil signed a songwriting contract with the Gerard Theatrical Agency on Sunset Strip. Beausoleil was given a key to the front door of the agency, and was allowed to use the tape recording equipment there to produce a demo. During

that spring, Beausoleil was cultivating a relationship with Dennis Wilson, Terry Melcher and Gregg Jakobson, with designs of furthering his musical career. In fact, Jakobson went twice to the Gerard Agency to listen to Bobby's tapes, and in April, Bobby stayed for about a week at Jakobson's house on North Beverly Glen.

There he met and later lived with a red-haired, seventeen-year old girl named Kitty Lutesinger. In late May of '69, Kitty became pregnant courtesy of Cupid, and moved to Spahn Ranch just in time to see Helter Skelter coming down fast. Beausoleil also approached Frank Zappa, asking him to come out to the ranch to hear the Family's music, but Zappa declined. Apparently, Zappa and Beausoleil had formed a loose relation-

ship during the early days of the Haight, and Bobby had even performed a cameo on Zappa's first album, "Freak-Out," as one of the people in the background of a song yelling: "We are the brain police!" and other assorted cacophonies.

The Gerard Agency specialized in supplying actors and actresses for porno flicks, and topless dancers for nightclubs. After hearing Bobby talk about the agency, Bill Vance—acting as "agent" for Sadie, Yeller, Stephanie, Katie, and Mary—was able to secure employment for the girls as dancers at strip joints in the valley. Charlie encouraged them to take the jobs in order to buy vehicles and other supplies for their grand return to the desert. Former Family associate Allen "Fats" Walts, who would roam the streets with Charlie while

the girls danced and panhandled to support their messiah, claims that he and Manson used to go up to the home of Dean Martin, and that "Charlie delivered drugs there."

During this same period, Charlie and some of his girls made a porno movie by a swimming pool at the Malibu property of a Mrs. Gibson. The producer, according to Los Angeles homicide officers, was some guy named Marvin Miller. Mrs. Gibson, after receiving numerous complaints from her neighbors, inspected her house in the company of a lawyer and discovered a bloody machete, which police said Manson used to slash somebody's arm during the course of the filmmaking.

Karate Dave, a twenty-six year old Vietnam vet, was another heavy-duty recruit who hooked up with the Family during the Yellow Submarine period, and lived in a tree house in the backyard with Bo Rosenberg. It

The White Album became such an influence upon The Family that various expressions from Beatles lyrics punctuated their speech.

was through Dave and Bill Vance that other outlaw types were enlisted to help the Family prepare for Operation Helter Skelter. These were guys who could score motor parts, camping gear and building supplies, and who would later work around the clock on various projects at Spahn Ranch. As the months passed, preparations for Helter Skelter accelerated, and though Manson rarely allowed this fringe biker and ex-con element into the inner circle of the Family, he was able to keep them around through the enticements of dope and sex.

By the middle of March, the Family had acquired three dune buggies and three Harleys. In addition, Charlie bought \$300 worth of topographical maps so they could chart an escape into the desert. The escape route began behind Spahn Ranch, and ran up into the Santa Susana Mountains by way of Devil's Canyon, and through Simi Valley, bypassing highways, going over and under culverts, across the Mojave Desert and eventually leading out to Death Valley.

This clandestine route was to be used at the time of Helter Skelter, when everything was going crazy in the cities and the highways leading out of L.A. would be in a violent gridlock. It was an escape route that would be a quick exit away from the chaos.

The Fab Four Angels

According to Paul Watkins, in *My Life With Charles Manson*, it was at the Gresham Street pad that Charlie started getting into the Beatles, particularly *The White Album*, which he interpreted as modern day prophecy, and the Beatles themselves as messengers of the Apocalypse retitled Helter Skelter. Charlie spent endless hours quoting Revelation to the Family, specifically the verse from Chapter 9:

*And the four angels were loosed
Which were prepared for an hour
And a day, and a month, and a year,
For to slay the third part of man
And the fifth angel sounded,
And I saw a star fall from heaven
Unto the earth: and to him was
Given the key to the bottomless pit.*

For those with ears to hear, the implications were quite clear: the four angels were the Beatles, and the fifth angel was Charlie! The "third part of man" was the white race; those who would die in the resultant carnage of Helter Skelter, wiped out for "worship of idols of

gold, silver, bronze, stone and wood," (Verse 20) which Charlie related to cars, houses, and money; the modern idols worshipped by piggies. The passage "And he opened the bottomless pit ... and there came out of the smoke locusts upon the earth; and unto them was given power as the scorpions of the earth have power" was not only a reference to the Beatles (i.e. locusts) but also implied that the power of the scorpion would prevail (Charlie was a Scorpio). Manson found references to dune buggies, as well as the motorcycle gangs he was trying to recruit, in such passages as "horses prepared to battle" and horsemen that would roam the earth, spreading destruction.

In describing the locusts (Beatles), Revelation said that "their faces were as the faces of men," yet "they had the hair of women," and wore "breastplates of fire," which Charlie interpreted as electric guitars. Another verse from Revelation spoke of "fire and brimstone"

coming from the mouths of the four angels, which Charlie interpreted as an allusion to the power of The Beatles' music and lyrics. Some have suggested that it really wasn't Charlie who invented Helter Skelter, but that he just became hip to the concept through channeled messages via the Beatles. Other apocalyptically inclined cults in California of the period held similar beliefs regarding an impending eschatological disaster, so the Family was not unique in this respect.

The White Album

In the same manner that Manson became a

self-styled student of the Bible, likewise he threw himself into interpreting *The White Album*, which he listened to with headphones as a means to decipher the messages hidden in the vinyl grooves. Soon, it has been suggested, Manson began to hear the Beatles whispering to him: "Charlie, Charlie, send us a telegram," on the song "Revolution #9." At one point, Manson actually did try to call the Beatles in London, but was unsuccessful contacting them.

Charlie felt that the Beatles were beaming subliminal messages that, on a conscious level, were perhaps unknown even to the Fab Four themselves.

The White Album became such an influence upon the Family that various expressions from Beatles lyrics punctuated their speech. It was all there, Charlie would tell them; just listen to the music. Didn't they have a song called "Sexy Sadie" that described Susan Atkins to a tee, not long after Charlie himself had christened her Sadie Mae Glutz? Didn't the Beatles tell blackie it was time for him to rise up when they sang: "Blackbird singing in the dead of night ... All your life, you were waiting for this moment to arise"? Not only that, but according to Charlie the Beatles knew that he was out in Los Angeles, and were urging him to speak out, to sing the truth to the world, in their song "Honey Pie": "Oh

In his book, *Big Secrets*, William Poundstone analyzed separately each overlaid track of "Revolution #9," backward and forward, discovering several interesting sound bites, none of which constituted actual backward masking.

honey pie, my position is tragic, Come and show me the magic of your Hollywood song."

In "Honey Pie," the Beatles even went so far as to beg Charlie to come to

England: "Oh honey pie, you are driving me frantic, sail across the Atlantic to be where you belong."

Charlie felt that the Beatles were beaming

subliminal messages that, on a conscious level, were perhaps unknown even to the Fab Four themselves.

During the Tate/LaBianca trial, Manson

was quoted as saying: "I think it's a subconscious thing. I don't know whether they did it or not. But it's there. It's an association in the subconscious. This music is bringing on the revolution, the unorganized overthrow of the Establishment. The Beatles know in the sense that the subconscious knows."

According to Tex Watson and Paul Watkins, Manson's interpretation of The White Album was much

more significant than Charlie was willing to later admit. It was their contention that The White Album was both a message to this "returned Jesus" (Charlie) to speak out, to call the chosen, and as a preparation for Helter Skelter. According to the Manson mythos, the Beatles were setting the stage for Charlie's message, and Charlie himself was to give the world an album that would light the fuse the Beatles had prepared. This album would contain message songs with subtle symbols aimed at different parts of society involved in the changes that were coming. Charlie's album would contain the "plan" which the Beatles were asking him to reveal in the song "Revolution #1." In the song "I Will," the Beatles urge Manson to speak the word: "And when at last I find you, Your song will fill the air, Sing it loud so I can hear you, Make it easy to be near you."

Following is a list of other songs from The White Album that Manson allegedly interpreted as direct messages from the four angels:

- "Happiness is a Warm Gun" which instructed the Family to arm themselves for the coming race war.
- "Piggies" was all about fat rich capitalists pigs and how they deserved a "damn good whacking," which is exactly what the blacks were going to give them, according to Charlie. The verse about piggies eating bacon with forks and knives might have, in fact, been acted out by the murdering Mansonoids as a form of "Aesthetic Terrorism" a la Leno LaBianca with a fork stuck in his stomach. "Pig" was written at the Tate residence, and "Death to Pigs" was written at the LaBianca's home.
- "Rocky Raccoon" was another reference to blacks.
- "Helter Skelter" was a prophecy about Manson emerging from the bottomless pit. "Helter Skelter" [sic] was written on the walls at the LaBianca's home.

Number nine, number nine, number nine...

Easily the most experimental piece on The White Album is John Lennon's mind-blowing cacophony, "Revolution #9," the apparent result of ingesting handfuls of LSD-25 tabs and spending long hours with scattered tape loops feeding them backward and forwards through reel to reel machines. "Revolution #9" took on great significance to Manson, who equated it with Revelation 9.

In his book, *Big Secrets*, William Poundstone analyzed separately each overlaid track of "Revolution #9," backward and forward, discovering several interesting sound bites, none of which constituted actual backward masking. These were, most likely, inadvertent accidents that found their way to vinyl by sheer dumb luck, when Lennon fed tape splices from BBC archived recordings into reel-to-reel machines. Because of this unorthodox

recording process, many were led to believe, including Charlie, that hidden messages had been deliberately inserted as backward masked subliminals: a strange collage of taped sounds—warfare, church hymns, crying babies, football games, BBC announcers, and rock music—thrown together in overlapping anarchic patterns.

One example of backward masked subliminals is of a high strung voice screaming, "Let me out! Let me out!" Many took this as an allusion to Paul McCartney in his totaled Aston Martin, screaming for help as he lay dying in the wreckage. This was a popular Beatle rumor of the day: that McCartney had died sometime prior to the Sgt. Pepper album, and an impostor, Billy Shears, had been brought in to take his place.

By far the most well-known and mind-blowing message to be found in "Revolution #9" is the "Number Nine-Turn Me On Dead Man" phonetic reversal, which Poundstone says is a quite common reversal, adding in his analysis that there was nothing special done in the recording process to have made this phenomenon occur. Anyone, Poundstone goes on to explain, who records their voice, saying, "Number Nine" and plays it backward will achieve the same effect: "Turn me on, dead man."

Like Manson, the number 9 held great significance in John Lennon's life. In numerology, 9 is the final number, the last single digit and highest counting number before starting over again; the beginning and the end. It was perhaps for these reasons that Lennon felt himself tuned into number 9, understanding the importance it played in his life.

Lennon's numerological odyssey began with his birth on October 9, 1940; his son Sean was also born on October 9. As a Liverpudlian lad, Lennon grew up in England at 9 Newcastle Road. Brian Epstein discovered the Beatles on November 9, 1961. The Beatles played their first gig at the Cavern Club in '61. Nine years later—in 1970—they officially split up. The group rocketed to superstardom after appearing on the Ed Sullivan Show on February 9, 1964. Several of Lennon's tunes featured the number 9 theme, such as "Revolution #9" on the White Album and "Number 9 Dream" from Walls and Bridges. John married Yoko in '69. (He met her on November 9, 1966.) They moved from England to New York in '71, and lived there for nine years, until Lennon was shot to death outside the entrance of The Dakota on December 8, 1980. After receiving the fatal gunshots, Lennon was transported to Roosevelt Hospital on 9th Street, and was officially pronounced dead at 11:07 pm (1+1+7=9). In England, John's birthplace, it was already December 9.

The Dakota Building is located on West 72nd Street. (7+2=9) The Lennon's apartment number at The Dakota was 72 (7+2=9). Above Lennon's bed at the Dakota hung the number 9. Eerily enough, one of the apartment

buildings Lennon purchased at The Dakota was used in the making of Roman Polanski's occult classic, *Rosemary's Baby*. According to author R. Gary Patterson, when Lennon discovered the *Rosemary's Baby* connection, he purportedly wrote "Helter Skelter" on the wall in the apartment, then moved a file cabinet in front of the wall to hide the words.

The Beatles' last album, *Abbey Road*, was recorded in 1969. In '69, Lennon officially changed his name from John Winston Lennon to John Ono Lennon, bragging that between John Ono Lennon and Yoko Ono Lennon there were nine O's. Lennon claimed to have seen a UFO while standing on the roof of The Dakota at 9 a.m. John and Yoko's Tarot card reader performed a pagan nuptial ceremony in '75 to celebrate their 6th wedding anniversary; the ceremony commenced at 9 p.m.

August 8th and 9th—when the Tate killings occurred—coincide with other significant dates in human history:

- On August 9, 1945, the atomic bomb was dropped on Nagasaki effectively drawing World War II to an Apocalyptic end.
- On August 8, 1907, famed cannibalistic serial killer Ed Gein—on whom Hitchcock's *Psycho* was loosely based—was born.
- On August 8, 1985, the LAPD first announced that the Night Stalker—a Satanic serial killer—was haunting the city.
- On August 8, 1974, Richard Milhous Nixon became the first President in history to resign from office.
- On August 8, 1969, Disneyland opened the doors to a new attraction, The Haunted Mansion. Later that night, macabre history was made again on 10050 Cielo Drive when Sharon Tate and her house guests were murdered. The next evening, on August 9, the Mansonoids paid a visit to the LaBianca's house, which had been owned by Walt Disney. •

Like Manson, the number 9 held great significance in John Lennon's life. In numerology, 9 is the final number, the last single digit and highest counting number before starting over again; the beginning and the end.

©Adam Gorightly is a "crackpot historian" of the very hippest sort. He is the author of the 573 page comprehensive Manson tome *The Shadow Over Santa Susana: Black Magic, Mind Control and The Manson Family Mythos*, which may be ordered through his website, www.mansonmythos.com. Illustrations by Eric York.

The author may be reached at gorightly@hotmail.com



THE HIDDEN FACE *of Terrorism*

By
Paul David Collins

In November 1989, Father Ignacio Martin-Baro, a social psychologist, delivered a speech in California on “The Psychological Consequences of Political Terror.” In his speech, Martin-Baro gave a precise definition of terrorism, one that is ignored only at great peril. Noam Chomsky provides a synopsis of this speech:

He (Martin-Baro) stressed several relevant points. First, the most significant form of terrorism, by a large measure, is state terrorism—that is, “terrorizing the whole population through systematic actions carried out by the forces of the state.” Second, such terrorism is an essential part of a “government-imposed sociopolitical project” designed for the needs of the privileged (Chomsky 386).

Disturbing though it may be, Martin-Baro’s definition is one validated by history. The majority of terrorist acts throughout history have found their sponsors in the

hallowed halls of officialdom, in the entity known as government. Terrorism is surrogate warfare, a manufactured crisis designed to induce social change. Its combatants consciously or unconsciously wage the war on behalf of higher powers with higher agendas. Whether its adherents are aware of it or not, terrorism always serves the ambitions of another.

Revolutionary Parliamentarianism

In his book, *And Not a Shot is Fired*, Jan Kozak describes “revolutionary parliamentarianism” or “the pincer movement.” Kozak explains:

A preliminary condition for carrying out fundamental social changes and for making it possible that parliament be made use of for the purpose of transforming a capitalistic society into a socialistic one, is: (a) to fight for a firm parliamentary majority which would ensure and develop a strong ‘pressure from above,’ and (b) to see to it that this firm parliamentary majority should rely on the revolutionary activity of the broad working masses exerting ‘pressure from below’ (Kozak 16).

Researcher Ralph Epperson elaborates:

The first step consisted of having the conspiracy's own people infiltrate the government [i.e. the "pressure from above."]

The second step was to create a real or alleged grievance, usually through either an action of government or through some situation where the government should have acted and didn't.

The third step consisted in having a mob created by the real or alleged grievance that the government or the conspiracy caused demand that the problem be solved by a governmental action [i.e. the "pressure from below."]

The fourth step consisted in having the conspirators in the government remedy the real or alleged situation with some oppressive legislation.

The fifth step is a repeat of the last three. The government does not solve the problem and the mob demand more and more legislation until the government becomes totalitarian in nature by possessing all of the power (Epperson 37).

A variation of this very same strategy is being employed in the United States as part of a "government-imposed sociopolitical project."

Manufacturing the Threat

As stated above, a grievance must be created through government action or inaction. In this case, the creation of a terrorist threat would provide the government with a crisis it could exploit. The story of the dreaded al-Qaeda terrorist network actually begins with Zbigniew Brzezinski, President Carter's national security advisor and first director of the Trilateral Commission. In his 1997 book, *The Grand Chessboard*, Brzezinski provides readers with the motivation for the creation of a terrorist threat. He begins:

The last decade of the twentieth century has witnessed a tectonic shift in world affairs. For the first time ever, a non-Eurasian power has emerged not only as a key arbiter of Eurasian power relations but also as the world's paramount. The defeat and collapse of the Soviet Union was the final step in the rapid ascendance of a Western Hemisphere power, the United States, as the sole and, indeed, the first truly global power... (Brzezinski xii).

Brzezinski celebrates the fact that America is being transformed into a world empire. However, he identifies a distinct threat to America's ascendancy to the position of sole global power: "The attitude of the American public toward the external projection of American power has been much more ambivalent" (Brzezinski 24). Apparently, the citizenry's aversion towards imperialistic policies, which Brzezinski euphemistically interprets as ambivalence, is an obstacle to the empire's expansion. After all, there are still plenty of patriots who understand that Brzezinski's expansionistic "geostrategy" is irreconcilable with the tenets of Americanism. Therefore, public opinion must be altered. At this pivotal juncture, Brzezinski cites a very interesting historical example: "The public supported America's engagement in World War II largely because of the shock effect of the Japanese attack on Pearl Harbor (Brzezinski 25)."

Ah, an option presents itself! Mass consensus could be facilitated through mass trauma. In fact, the engineer-

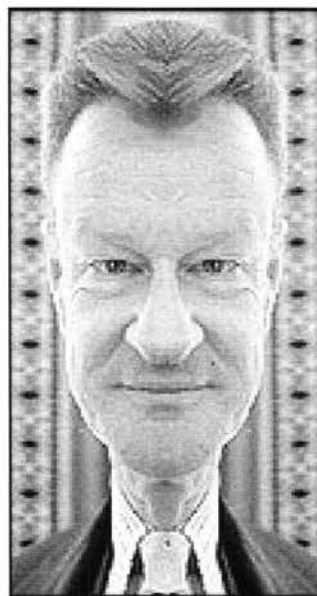

"America may find it more difficult to fashion a consensus on foreign policy issues, except in the circumstance of a truly massive and widely perceived direct external threat."

-- Zbigniew Brzezinski, 1997, President Carter's National Security Advisor and first director of the Trilateral Commission

ing of widespread compliance is an essential constituent in the implementation of Brzezinski's foreign policy. In an exemplary moment of self-incrimination so endemic to elitist tracts, Brzezinski pens a damning confession:

Moreover, as America becomes an increasingly multi-cultural society, it may find it more difficult to fashion a consensus on foreign policy issues, except in the circumstance of a truly massive and widely perceived direct external threat (Brzezinski 211).

A readily exploitable menace, whether genuine or promulgated, is the solution. Brzezinski began the construction of his "direct external threat" years before *The Grand Chessboard* was written. In an interview with the French magazine *Le Nouvel Observateur*, the former national security advisor made a stunning confession that will change the history books forever:

Q: The former director of the CIA, Robert Gates, stated in his memoirs ["From the Shadows"], that American intelligence services began to aid the Mujahadeen in Afghanistan six months before the Soviet intervention. In this

period you were the national security adviser to President Carter. You therefore played a role in this affair. Is that correct?

Brzezinski: Yes.

According to the official version of history, CIA aid to the Mujahadeen began during 1980, that is to say, after the Soviet army invaded Afghanistan, 24 Dec 1979. But the reality, secretly guarded until now, is completely otherwise: Indeed, it was July 3, 1979 that President Carter signed the first directive for secret aid to the opponents of the pro-Soviet regime in

Kabul. And that very day, I wrote a note to the president in which I explained to him that in my opinion this aid was going to induce a Soviet military intervention.

Q: Despite this risk, you were an advocate of this covert action. But perhaps you yourself desired this Soviet entry into war and looked to provoke it?

B: It isn't quite that. We didn't push the Russians to intervene, but we knowingly increased the probability that they would (Blum 1)

Having encouraged the Soviets to invade Afghanistan, Brzezinski now had a pretext for radicalizing and arming a population that would be used at a future date as a "direct external threat" to the United States. Part of the radicalization process included the brainwashing of children under the guise of education. *The Washington Post's* Joe Stephens and David B. Ottaway report:

In the twilight of the Cold War, the United States spent millions of dollars to supply Afghan schoolchildren with textbooks filled with violent images and

militant Islamic teachings, part of covert attempts to spur resistance to the Soviet occupation. The Primers, which were filled with talk of jihad and featured drawings of guns, bullets, soldiers and mines, have served since then as the Afghan school system's core curriculum. Even the Taliban used the American-produced books, though the radical movement scratched out human faces in keeping with its strict fundamentalist code (Stephens 1-2).

Stephens and Ottaway identify the governmental and educational organizations involved in the development of the textbooks:

Published in the dominant Afghan languages of Dari and Pashtu, the textbooks were developed in the early 1980s under an AID [Agency for International Development] grant to the University of Nebraska-Omaha and its Center for Afghanistan Studies. The agency spent \$51 million on the university's education programs in Afghanistan from 1984 to 1994 (Stephens 4).

Under this project, the images and talk of violence were craftily intermingled with legitimate education:

Children were taught to count with illustrations showing tanks, missiles and land mines, agency officials said. They acknowledged that at the time it also suited U.S. interests to stoke hatred of foreign invaders (Stephens 4).

One aid worker's examination of a textbook produced shocking results: "An aid worker in the region reviewed an unrevised 100-page book and counted 43 pages containing violent images or passages (Stephens 5)." *The Washington Post* writers go on to provide an example of the material that is nothing less than appalling:

One page from the texts of that period shows a resistance fighter with a bandolier and a Kalashnikov slung from his shoulder. The soldier's head is missing.

This social engineering project successfully transformed Muslim children into conscienceless killing machines. Many would go on to join al-Qaeda, the terrorist network headed up by Osama bin Laden.

Above the soldier is a verse from the Koran. Below is a Pashtu tribute to the mujaheddin [sic], who are described as obedient to Allah. Such men will sacrifice their wealth and life itself to impose Islamic law on the government, the text says (Stephens 5-6).

This social engineering project successfully transformed Muslim children into conscienceless killing machines. Many would go on to join al-Qaeda, the terrorist network headed up by Osama bin Laden. An heir to Saudi construction fortune, Bin Laden went to Afghanistan in 1979 to fight the Soviets. Bin Laden eventually came to head the Maktab al-Khidamar, also known as the MAK. It was through this front organization that money, arms, and fighters were supplied to the Afghan war (Moran 2).

However, according to MSNBC's Michael Moran, there is more to the story:

What the CIA bio conveniently fails to specify (in its unclassified form, at least) is that the MAK was nurtured by Pakistan's state security services, the Inter-Services Intelligence agency, or ISI, the CIA's primary conduit for conducting the covert war against Moscow's occupation (Moran 2).

Even after the war Bin Laden was on good terms with the CIA:

Though he has come to represent all that went wrong with the CIA's reckless strategy there, by the end of the Afghan war in 1989, bin Laden was still viewed by the agency as something of a dilettante—a rich Saudi boy gone to war and welcomed home by the Saudi monarchy he so hated as something of a hero (Moran 3).

Whether Moran realizes it or not, his article "Bin Laden Comes Home to Roost" reveals evidence that the Agency may have been equipping Bin Laden's network

for purposes other than fighting the Soviets:

The CIA, ever mindful of the need to justify its "mission," had conclusive evidence by the mid-1980s of the deepening crisis of infrastructure within the Soviet Union. The CIA, as its deputy director Robert Gates acknowledged under congressional questioning in 1992, had decided to keep that evidence from President Reagan and his top advisors and instead continued to grossly exaggerate Soviet military and technological capabilities in its annual "Soviet Military Power" report right up to 1990 (Moran 4).

Now, a troubling question arises. Given the impending collapse of the Soviet Union and the inexorable demise of communism, Bin Laden's involvement in the



"A Kalashnikov bullet travels at 800 meters per second. A mujahed has the forehead of a Russian in his sights 3200 meters away. How many seconds will it take the bullet to hit the Russian's forehead?"

(Quote from Afghanistan textbook written by the University of Nebraska and distributed by the CIA)

Laden and his al-Qaeda network, provided the pretext for this move.

The Third Option

Yet another sector of the Establishment had much to gain by creating a readily exploitable crisis: the intelligence community. In his book, *See No Evil*, former CIA man Robert Baer records the following:

The other day a reporter friend told me that one of the highest ranking CIA

crusade against the Soviets seems irrelevant. Yet, despite his clear obsolescence in the anti-communist campaign, Bin Laden continued to receive funds. Since such financing did not represent an investment in the ongoing war with the Soviets, there must have been ulterior motives for maintaining Bin Laden's network. Perhaps those motives can be seen in America's imperialistic flight forward into Afghanistan and Iraq, countries with oil resources that are strategically vital to the empire's primacy. The September 11 attacks, conducted by Bin

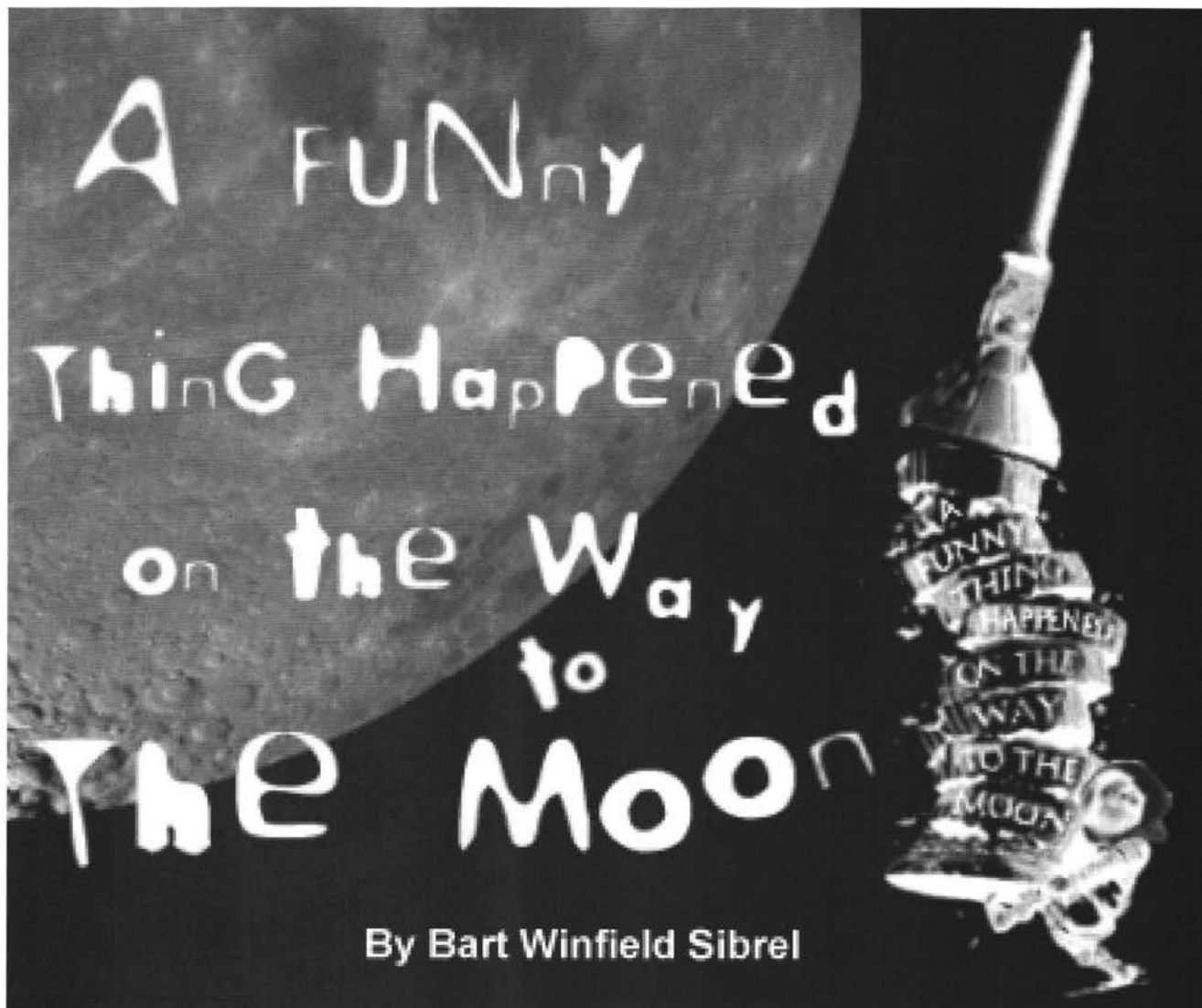

In this astonishing film, investigative journalist Bart Sibrel unearths in the NASA archives an unedited and mislabeled reel of footage, dated July 23, 1969, three days into the flight of Apollo 11. Remarkably, the exclusive footage in "A Funny Thing Happened on the Way to the Moon" shows the Apollo crew falsifying their photography. This raw footage, supposedly taken "halfway to the Moon," shows the crew taking pictures of the distant earth from the round portal window of the craft. But the truth is accidentally revealed when we see that the camera is not up against the window of the portal, but is set back a distance from the portal. In fact, the space craft is in low-earth atmosphere: the round portal window itself frames and, therefore, creates the illusion of a round blue earth much further away than it actually is! This incredibly awesome, professional and entertaining video is a must-see! When Apollo 11 astronaut Buzz Aldrin, who is believed to have shot the bogus footage, was recently shown the tape, he said, "Well you're talking to the wrong guy! Why don't you talk to the administrator at NASA? We're passengers!" Says journalist Bart Sibrel: "He then threatened to sue us if we showed it publicly." As Sibrel states, "Whatever sound and pictures were shown to the public were strictly controlled and previewed by the federal government before they were broadcast. - Joan d'Arc

When rivalry among nations first reared its envious head thousands of years ago, the conquest was which civilization could build the tallest building, albeit by one story. Sound familiar? The monumental goal was never met and the project, the Tower of Babel, was abandoned in disgrace.

At the dawn of the modern industrial revolution, the twentieth century, the largest single machine yet constructed by the hand of man was fashioned in 1912. It was boasted in print to be a marvel that, "God himself could not destroy." This great work of mankind, the Titanic, never even completed its first voyage. Richard Nixon was commander and chief during the reported Apollo landings on the moon. He called this historic occasion, "The greatest week since creation itself!"

I am Bart Winfield Sibrel, the writer, producer, director of "A Funny Thing Happened on the Way to the Moon" (www.moonmovie.com), a controversial documentary which questions the authenticity of the manned moon landings some thirty-four years ago. As an investigative journalist, I spent five years and \$500,000 researching this topic, which seems on the surface to be completely ludicrous. Then I came upon a highly-credible source, a man in his late 70s, whom I

the first Apollo mission. All three crew members of the first historic flight also resigned shortly thereafter. Neil Armstrong, the most famous astronaut and supposedly the first man on the moon, refused to appear in a single still picture on the moon! Aside from the initial press conference immediately following the event, in which he seems very disgruntled, he has not given a single interview on the subject, in print or on camera. Some photography allegedly from the moon contains shadows that intersect with each other. Yet, NASA claims only

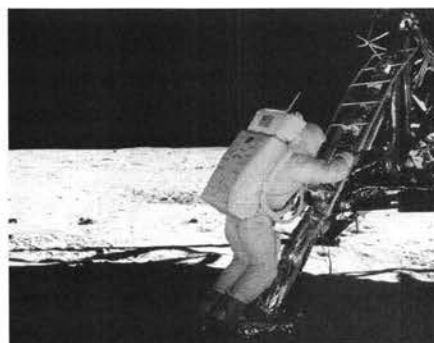

In this picture, the astronaut is in the shadow cast by the LM, yet every detail of him is clearly seen! This could only occur if artificial lighting was used.

sunlight was used and it always casts parallel shadows.

In my research at NASA I uncovered, deep in the archives, one mislabeled reel from Apollo 11, the first mission to the moon in July 1969. What I found on the reel and what was on the label are completely different. I suspect an editor put the wrong label on the tape

Even today an un-manned space probe the size of a toaster oven requires nearly ten years to develop. In hindsight, isn't this rather odd?

have verified worked for the space program during the 1960's. He asserted, most confidently, that the Apollo moon landings were first, impossible, and second, falsified as a Cold War tactic to bluff the Soviet Union into thinking the United States had greater capability than it really did.

I discovered that the highest ranking official at NASA resigned, without explanation, just days before

thirty-four years ago, and no reporter ever had the motive to be as thorough as I. The reel contains an hour of rare, unedited, color television footage that is dated, by NASA's own atomic clock, three days into the flight. Identified on camera are Neil Armstrong, Edwin "Buzz" Aldrin, and Michael Collins. They are doing multiple "takes" of a single shot of the mission, from which only about ten seconds was ever broadcast. Because I have



uncovered the original unedited version, mistakenly not destroyed, the photograph proves to be a clever forgery. It means they did not walk on the moon! (See "Uncovered Footage Described" at www.moonmovie.com.)

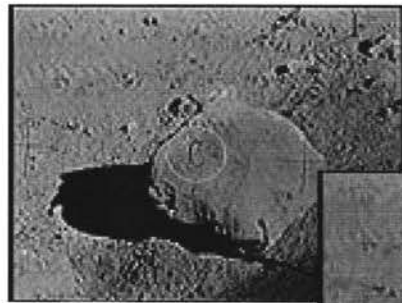

The original photo (left) of a lunar "rock" clearly has the letter "C" on it, the retouched photo (right) does not.

Also, the "rock" appears to have folds on the edges. Is this "moon rock" a prop?

A *USA Today* writer composed an article calling my assertion "impossible," without even viewing "A Funny Thing Happened on the Way to the Moon," which contains the unprecedented footage that I believe would prove the fraud in a court of law. A friend of mine brought to my attention a human condition called "Cognitive Dissonance." That is when someone has a long-held belief rooted so deeply in their psyche that they can not see anything else, even if visible facts prove contrary to their belief. The pride of the moon landings can certainly cloud people from seeing the distasteful truth. I showed this key footage to a retired military officer who believed in the moon landings. He actually

walked out of my house when he saw it! (See no evil.) I was "dissing" America in his mind, even if it was true.

American military and political leaders "dissed" their own country when they falsified history, by refusing to accept public defeat after John Kennedy pledged to "put a man on the moon by the end of the 1960's." "When pride comes, then comes disgrace." (Proverbs 11:2) The government had already spent an equivalent of \$135 billion of taxpayer's money, and to then disclose their inability to fulfill the boastful goal was apparently too much for their pride. There was a strategic advantage to the Soviet Union thinking the United States was capable of an actual trip to the Moon. It boosted national spirit during the Vietnam War. It made friends of friends in the government very, very rich.

Twenty years after Apollo, with much improved and superior technology than that of 1969, a mission only 1/100th as complicated—the earth orbit of the Hubble telescope—was nearly as many years behind schedule as the entire development of the lunar landing program. After five failed launch attempts, Hubble didn't even work when it arrived at its destination, which was only 1/1000th the distance to the moon. It took another two years to make the necessary repairs to get it operational. Even today an unmanned space probe the size of a toaster oven requires nearly ten years to develop. In hindsight, isn't this rather odd?

At the time, with the advent of color TV's, mobile phones and microwave ovens, was our faith in the technological era overconfident? Could a fuzzy black-and-white television image be used to fool the public? Let's look at history. In the mid 1950's, *Time* magazine featured on its cover "The Smartest Man in America," who was the latest winner of the popular TV game show "The Sixty-four Thousand Dollar Question." It was later proven in a court of law that the man knew the answers in advance!

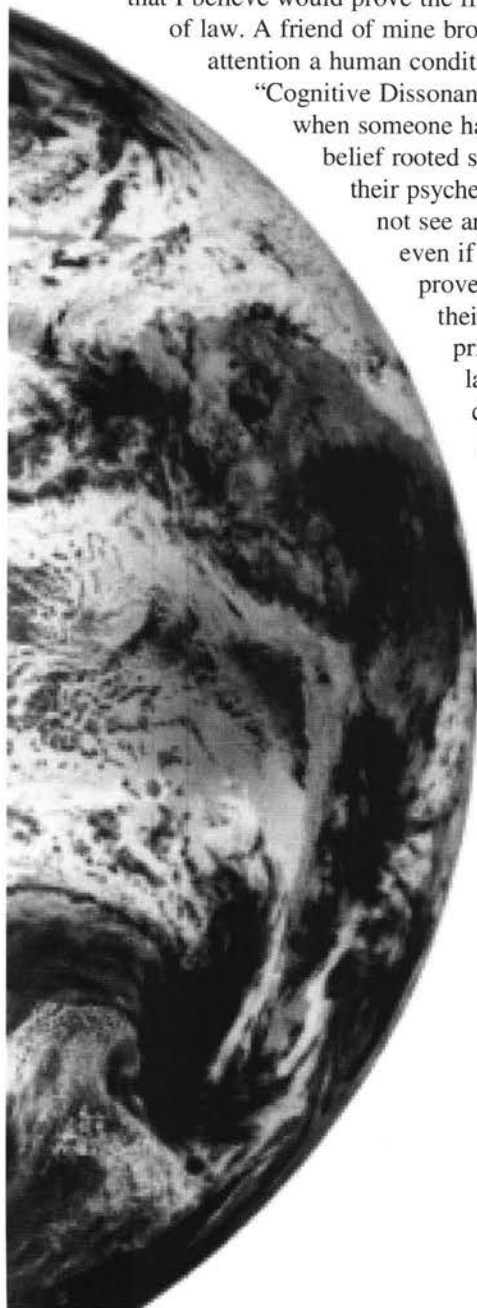

Time was wrong. The story on the cover of their magazine was a lie. The media was deceived. "One big manipulation" . . . for only sixty-four thousand dollars.

I believe that the chief motive for the Apollo cover-up was to fool the Soviet Union during the height of the Cold War into thinking that the US had superior technology that did not really exist. Pride, a Vietnam war distraction, and misallocation of funds made it most beneficial as well. At the dawn of the "Space Race," never before in history had two "superpowers" each possessed the missile capability to annihilate the other several times over from a location half way around the world. The Russians launched the first artificial satellite, the first man in space, the first man to orbit the earth, the first space walk, the first woman in space, the first crew of three into space, and the first of two simultaneously orbiting spacecraft. For every twenty hours the US spent in space, the Soviets spent one hundred! Five times the experience and, therefore, expertise.

In 1994, our own government's watchdog agency, the General Accounting Office, reported, "The Star Wars Missile Defense System rigged tests to make it seem more advanced than it really was. The aim was to fool the Soviet Union about US strategic capability during the Cold War." So much more was the need in 1969 for misinformation, when there was concern, now admittedly irrational, that "Sputnik 3" might contain nuclear missiles that would put the weapons less than ten minutes from major targets in America. If the US could put a man on the moon, maybe the Soviet Union would back off.

Never before in history had such a historic event occurred without independent press coverage. There were, after all, only three first-hand witnesses to each moon landing. Whatever sound and pictures were shown to the public were strictly controlled and previewed by the federal government before they were broadcast or distributed to the populace. They went up in the rocket for sure. They splashed down in the ocean for sure. The newly discovered footage, however, clearly proves that they stayed in earth orbit for the entire eight days of each Apollo mission. Anyone with an open mind can see that when the assassin of President Kennedy was

assassinated himself three days later, something was awry regardless of what appointed politicians told the public.

I believe that the chief motive for the cover-up was to fool the Soviet Union during the height of the Cold War into thinking that the US had superior technology that did not really exist.

Everyone who does wrong has their reasons. While the Cold War deception of advanced "Star Wars" technology, which did not really exist, seems irrelevant today, acknowledging to the public that the greatest achievement of the United States, and supposedly the world, was an outright fraud is more than our leaders have the character to admit.

George Orwell said, "Whoever controls the past, controls the future." That is why the truth must come out. As our national budget quadruples every year, those in power seem helpless to stop the beast they have created. When will it end? What will it take to stop it? Perhaps a revelation such as *The Moon Movie*? •

Bart Winfield Sibrel may be contacted at bart@moonmovie.com. The Moon Movie (in VHS or DVD) may be purchased for the low price of \$19.95 at <http://www.moonmovie.com/> or from: AFTH, LLC., P.O. Box 292962, Nashville, TN 37229-2962.

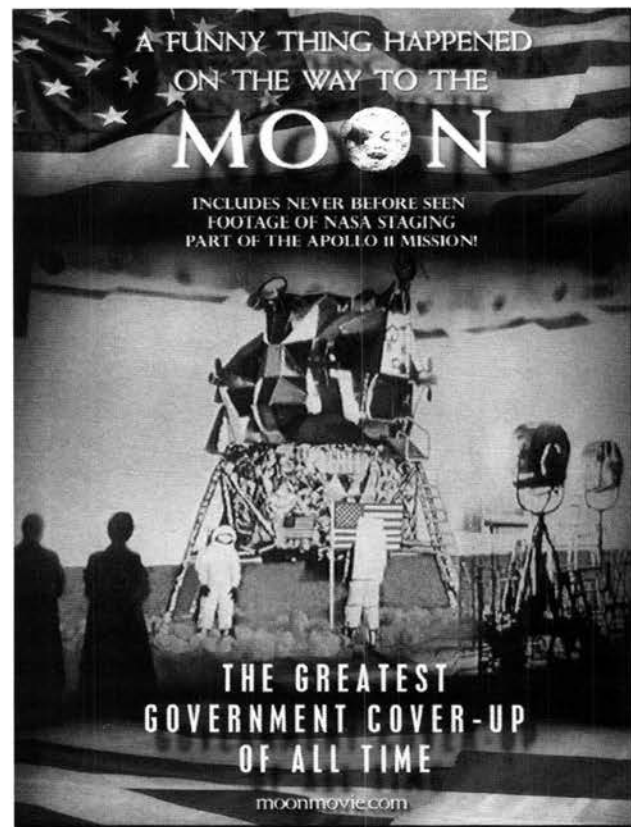

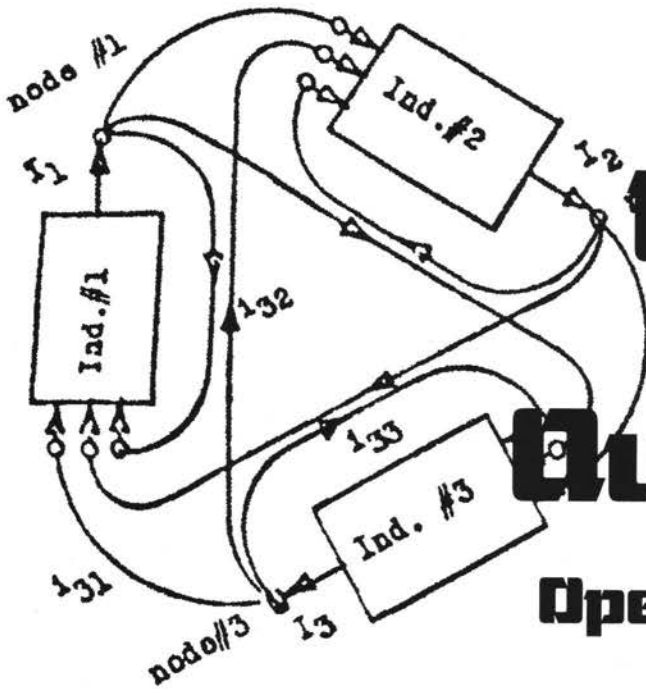

Silent Weapons for Quiet Wars

Operations Research Technical Manual

[TM-SW 7905.1]

With its bizarre claim to have been found in a surplus IBM copy machine in 1986 by a Boeing Aircraft employee, *Silent Weapons for Quiet Wars* takes its place among those dubious “elite blueprints” for control of the planet, such as the well-known treatise, *The Protocols of The Learned Elders of Zion*. Dated May 1979, *Silent Weapons* called for a “quiet revolution” through economic engineering, using such methods as economic shock testing and paper inductance/inflation (exchanging true value for inflated currency), and balancing the system by killing off the true creditors of this exchange (the public) in constant wars.

Silent Weapons was first published for mass consumption by the late great William Cooper in his 1991 underground sensation, *Behold a Pale Horse*. A few versions of this document later appeared on the Internet, along with remarks to the effect that the paranoid manifesto was probably penned by Cooper himself.(1) Cooper, a former Naval Intelligence Officer with a purported 38-level above-top secret clearance, claimed to have read this report in a “Naval Intelligence Majority Twelve file,” and that it was authored by the Bilderberg Group. Cooper states in his book that the manifesto was given to him by someone named Tom Young.

Here *Paranoia* offers an excerpt of the document, reprinting some of the original schematics and mathematical equations contained in the undated pamphlet we have had in our collection since approximately 1993. These sophisticated diagrams were not reproduced in Cooper’s book and their existence casts doubt on Cooper’s alleged authorship.

The economic analyses implicated in *Silent Weapons* could only have been made by someone with an advanced understanding of complex socioeconomic systems. William Cooper was not a trained economist. Further, if Cooper had written the document, why would he remove his own elaborate mathematical notations? Also, Cooper’s version does not contain the Preface that appears in the pamphlet (shown below). The Preface notes that the document is “reprinted in its virgin form, with diagrams,” and is described as “heavy reading.” However, it is possible the pamphlet was printed after Cooper got hold of his version of the document. The reason for removing the diagrams (and any mention of them) may have been that Cooper thought them too obscure for the grassroots patriot movement that was his audience. In addition, by renaming the document, “The Illuminati’s Declaration of War on the American People,” Cooper emphasized his patriot leanings and de-emphasized the more complicated mathematical elements of the “Illuminati” blueprint.

In short, while Cooper may have understood the complex diagrams in the manifesto, it is doubtful he had

the background to devise them. There are also other differences between the two versions: Cooper's version of *Silent Weapons* reproduced in *Pale Horse* contained his characteristic ALL CAPS for emphasis. The original pamphlet does not contain these. Cooper's version also inserts personal notes in brackets. We have not inserted Cooper's personal notes. This version reproduces some of the diagrams from our pamphlet, which are entirely missing from Cooper's version.

This rare and ambiguous document may very well be a hoax, but was it perpetrated by William Cooper or on William Cooper? If it's a hoax, who wrote it? Some suggestions might be Ted Kaczynski or perhaps the late anarcho-libertarian, Murray Rothbard. Strangely, the beginning of the document reflects some finesse on the part of the author, but by the end it deteriorates into a sociopathic "rant," which might indicate authorship by more than one person. Please send us your ideas.

Introduction by Joan d'Arc

Preface

Conspiracy Theories are nothing new to history. Plots to kill Caesar and overthrow Rome abounded, for instance. However, it is seldom that concrete clues to such plots come to light, and are generally known. The document you are about to read is real. It is no forgery, as is alleged of "The Protocols of the Learned Elders of Zion," or actual forgeries such as those of Anne Frank, or (more recently) Hitler's diary.

TOP SECRET: Silent Weapons for Quiet Wars, An Introductory Programming Manual was uncovered quite by accident on July 7, 1986 when an employee of Boeing Aircraft Co. purchased a surplus IBM copier for scrap parts at a sale, and discovered inside details of a plan, hatched in the embryonic days of the "Cold War," which called for control of the masses through manipulation of industry, people's pastimes, education and political leanings. It called for a quiet revolution, putting brother against brother, and diverting the public's attention from what is really going on.

For all intents and purposes, this document has "come to pass" much as Henry Ford, Sr. said that the Protocols (regardless of their veracity) applied to the events of his day. It is reprinted in its virgin form, with diagrams, as a touch of reality.

It is heavy reading, but it will (as it should) spur you to read further, keep your eyes and ears open, and sound an alarm in Zion, for though she presently dwells with Babylon's daughter (Micah 4), her redemption draweth nigh. Truth bears no fear.

Security

It is patently impossible to discuss social engineering or the automation of a society, i.e., the engineering of social automation systems (silent weapons) on a national or worldwide scale without implying extensive

objectives of social control and destruction of human life, i.e., slavery and genocide.

This manual is in itself an analog declaration of intent. Such a writing must be secured from public scrutiny. Otherwise, it might be recognized as a technically formal declaration of domestic war. Furthermore, whenever any person or group of persons in a position of great power and without full knowledge and consent of the public, uses such knowledge and methodology for economic conquest – it must be understood that a state of domestic warfare exists between said person or group of persons and the public.

The solution of today's problems requires an approach which is ruthlessly candid, with no agonizing over religious, moral or cultural values. You have qualified for this project because of your ability to look at human society with cold objectivity, and yet analyze and discuss your observations and conclusions with others of similar intellectual capacity without a loss of discretion or humility. Such virtues are exercised in your own best interest. Do not deviate from them.

Welcome Aboard

This publication marks the 25th anniversary of the Third World War, called the "Quiet War," being conducted using subjective biological warfare, fought with "silent weapons." This book contains an introductory description of this war, its strategies, and its weaponry. May 1979 #74-1120

Historical Introduction

Silent weapon technology has evolved from Operations Research (O.R.), a strategic and tactical methodology developed under the military management in England during World War II. The original purpose of Operations Research was to study the strategic and tactical problems of air and land defense with the objective of effective use of limited military resources against foreign enemies (i.e., logistics). It was soon recognized by those in positions of power that the same methods might be useful for totally controlling a society. But better tools were necessary.

Social engineering (the analysis and automation of a society) requires the correlation of great amounts of constantly changing economic information (data), so a high-speed computerized data-processing system was necessary which could race ahead of the society and predict when society would arrive for capitulation. Relay computers were too slow, but the electronic computer, invented in 1946 by J. Presper Eckert and John W. Mauchly, filled the bill.

The next breakthrough was the development of the simplex method of linear programming in 1947 by the mathematician George B. Dantzig. Then in 1948, the transistor, invented by J. Bardeen, W. H. Brattain, and W. Shockley, promised great expansion of the computer

field by reducing space and power requirements. With these three inventions under their direction, those in positions of power strongly suspected that it was possible for them to control the whole world with the push of a button.

Immediately, the Rockefeller Foundation got in on the ground floor by making a four-year grant to Harvard College, funding the Harvard Economic Research Project for the study of the structure of the American economy.

One year later, in 1949, the United States Air Force joined in. In 1952 the original grant period terminated, and a high-level meeting of the elite was held to determine the next phase of social operations research. The Harvard project had been very fruitful, as is borne out by the publication of some of its results in 1953 suggest-

$$\begin{aligned} \text{Node \#1 : } I_1 &= i_{11} + i_{12} + i_{13} = \sum_{k=1}^3 i_{1k} \\ \text{Node \#2 : } I_2 &= i_{21} + i_{22} + i_{23} = \sum_{k=1}^3 i_{2k} \\ \text{Node \#3 : } I_3 &= i_{31} + i_{32} + i_{33} = \sum_{k=1}^3 i_{3k} \end{aligned}$$

where \sum denotes $\sum_{k=1}^3$

ing the feasibility of economic (social) engineering. (*Studies in the Structure of the American Economy* – copyright 1953 by Wassily Leontief, International Sciences Press Inc., White Plains, New York.)

Engineered in the last half of the decade of the 1940s, the new Quiet War machine stood, so to speak, in sparkling gold-plated hardware on the showroom floor by 1954. With the creation

of the maser in 1954, the promise of unlocking unlimited sources of fusion atomic energy from the heavy hydrogen in sea water and the consequent availability of unlimited social power was a possibility only decades away. The combination was irresistible.

The quiet war was quietly declared by the international elite at a meeting held in 1954. Although the silent weapons system was nearly exposed 13 years later, the evolution of the new weapon-system has never suffered any major setbacks. This volume marks the 25th anniversary of the beginning of the Quiet War. Already this domestic war has had many victories on many fronts throughout the world.

Political Introduction

In 1954 it was well recognized by those in positions of authority that it was only a matter of time, only a few decades, before the general public would be able to

grasp and upset the cradle of power, for the very elements of the new silent-weapon technology were as accessible for a public utopia as they were for providing a private utopia.

The issue of primary concern, that of dominance, revolved around the subject of the energy sciences.

Energy

Energy is recognized as the key to all activity on earth. Natural science is the study of the sources and control of natural energy, and social science, theoretically expressed as economics, is the study of the sources and control of social energy. Both are bookkeeping systems: mathematics. Therefore, mathematics is the primary energy science. And the book-keeper can be king if the public can be kept ignorant of the methodology of the bookkeeping. All science is merely a means to an end. The means is knowledge. The end is control. Beyond this remains only one issue: Who will be the beneficiary?

In 1954 this was the issue of primary concern. Although the so-called "moral issues" were raised, in view of the law of natural selection it was agreed that a nation or world of people who will not use their intelligence are no better than animals who do not have intelligence. Such people are beasts of burden and steaks on the table by choice and consent.

Consequently, in the interest of future world order, peace, and tranquility, it was decided to privately wage a quiet war against the American public with an ultimate objective of permanently shifting the natural and social energy (wealth) of the undisciplined and irresponsible many into the hands of the self-disciplined, responsible, and worthy few. In order to implement this objective, it was necessary to create, secure, and apply new weapons which, as it turned out, were a class of weapons so subtle and sophisticated in their principle of operation and public appearance as to earn for themselves the name "silent weapons."

The objective of economic research, as conducted by the magnates of capital (banking) and the industries of commodities (goods) and services, is the establishment of an economy which is totally predictable and manipulatable. In order to achieve a totally predictable economy,

The public might instinctively feel that something is wrong, but because of the technical nature of the silent weapon they cannot express their feeling in a rational way.

the low-class elements of the society must be brought under total control, i.e., must be housebroken, trained, and assigned a yoke and long-term social duties from a very early age, before they have an opportunity to question the propriety of the matter.

In order to achieve conformity, the lower-class family unit must be disintegrated by a process of increasing preoccupation of the parents and the establishment of government-operated daycare centers for the occupationally orphaned children. The quality of education given to the lower class must be of the poorest sort, so that the moat of ignorance isolating the inferior class from the superior class is and remains incomprehensible to the inferior class. With such an initial handicap, even bright lower class individuals have little if any hope of extricating themselves from their assigned lot in life. This form of slavery is essential to maintaining some measure of social order, peace, and tranquility for the ruling upper class.

Descriptive Introduction of the Silent Weapon

Everything that is expected from an ordinary weapon is expected from a silent weapon by its creators, but only in its own manner of functioning. It shoots situations, instead of bullets; propelled by data processing, instead of a chemical reaction (explosion); originating from bits of data, instead of grains of gunpowder; from a computer, instead of a gun; operated by a computer programmer, instead of a marksman; under the orders of a banking magnate, instead of a military general.

It makes no obvious explosive noises, causes no obvious physical or mental injuries, and does not obviously interfere with anyone's daily social life. Yet it makes an unmistakable "noise," causes unmistakable physical and mental damage, and unmistakably interferes with daily social life, i.e., unmistakable to a trained observer, one who knows what to look for. The public cannot comprehend this weapon, and therefore cannot believe that they are being attacked and subdued by a weapon.

The public might instinctively feel that something is wrong but because of the technical nature of the silent weapon, they cannot express their feeling in a rational way, or handle the problem with intelligence. Therefore, they do not know how to cry for help, and do not know how to associate with others to defend themselves against it. When a silent weapon is applied gradually, the public adjusts/adapts to its

presence and learns to tolerate its encroachment on their lives until the pressure (psychological via economic) becomes too great and they crack up.

Therefore, the silent weapon is a type of biological warfare. It attacks the vitality, options, and mobility of the individuals of a society by knowing, understanding, manipulating, and attacking their sources of natural and social energy, and their physical, mental, and emotional strengths and weaknesses.

Theoretical Introduction

"Give me control over a nation's currency, and I care not who makes its laws."

– Mayer Amschel Rothschild (1743 – 1812)

Today's silent weapons technology is an outgrowth of a simple idea discovered, succinctly expressed, and effectively applied by the quoted Mr. Mayer Amschel Rothschild. Mr. Rothschild discovered the missing passive component of economic theory known as economic inductance. He, of course, did not think of his discovery in these 20th-century terms, and, to be sure, mathematical analysis had to wait for the Second Industrial Revolution, the rise of the theory of mechanics and electronics, and finally, the invention of the electronic computer before it could be effectively applied in the control of the world economy.

General Energy Concepts

In the study of energy systems, there always appear three elementary concepts. These are potential energy, kinetic energy, and energy dissipation. In economics these three energy concepts are associated with: (1) Economic Capacitance: Capital (money, stock/inventory, investments in buildings and durables, etc.) (2) Economic Conductance: Goods (production flow coefficients) (3) Economic Inductance: Services (the influence of the population of industry on output). All of the mathematical theory developed in the study of one energy system (e.g., mechanics, electronics, etc.) can be immediately applied in the study of any other energy system (e.g., economics).

Mr. Rothschild's Energy Discovery

What Mr. Rothschild had discovered was the basic principle of power, influence, and control over people as applied to economics. That principle is "when you assume the appearance of power, people soon give it to you." Mr. Rothschild had discovered that currency or deposit loan accounts had the required appearance of power that could be used to

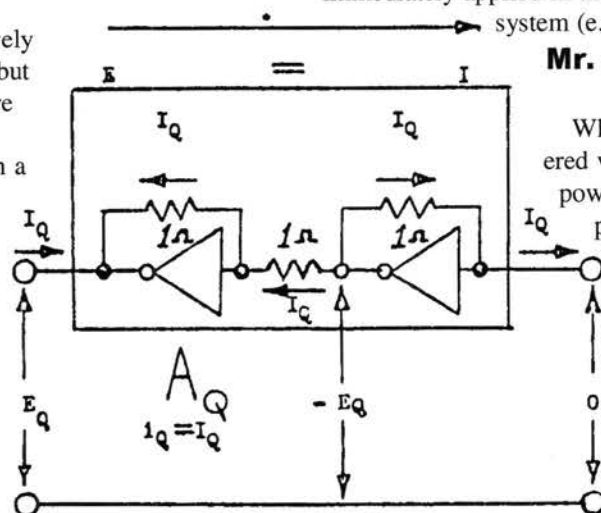

induce people (inductance, with people corresponding to a magnetic field) into surrendering their real wealth in exchange for a promise of greater wealth (instead of real compensation). They would put up real collateral in exchange for a loan of promissory notes.

Mr. Rothschild found that he could issue more notes than he had backing for, so long as he had someone's stock of gold as a persuader to show to his customers.

Mr. Rothschild loaned his promissory notes to individuals and to governments. These would create overconfidence. Then he would make money scarce, tighten control of the system, and collect the collateral through the obligation of contracts. The cycle was then repeated. These pressures could be

used to ignite a war. Then he would control the availability of currency to determine who would win the war. That government which agreed to give him control of its economic system got his support. Collection of debts was guaranteed by economic aid to the enemy of the debtor. The profit derived from this economic methodology made Mr. Rothschild all the more able to extend his wealth. He found that the public greed would allow currency to be printed by government order beyond the limits (inflation) of backing in precious metal or the production of goods and services (gross national product, GNP).

Apparent Capital As "Paper" Inductor

In this structure, credit, presented as a pure element called "currency" has the appearance of capital, but is, in fact, negative capital. Hence, it has the appearance of service, but is, in fact, indebtedness or debt. It is therefore an economic inductance instead of an economic capacitance, and if balanced in no other way, will be balanced by the negation of population (war, genocide). The total goods and services represent real capital called the gross national product, and currency may be printed up to this level and still represent economic capacitance; but currency printed beyond this level is subtractive, represents the introduction of economic inductance, and constitutes notes of indebtedness. War is therefore the

balancing of the system by killing the true creditors (the public which we have taught to exchange true value for inflated currency) and falling back on whatever is left of the resources of nature and regeneration of those resources.

Mr. Rothschild had discovered that currency gave him the power to rearrange the economic structure to his own advantage, to shift economic

inductance to those economic

positions which would encourage the greatest economic instability and oscillation. The final key to economic control had to wait until there was sufficient data and high-speed computing equipment to keep close watch on the economic oscillations created by price shocking and excess paper energy credits – paper inductance/inflation.

Application In Economics

[To apply] the method of airframe shock testing

to economic engineering, the

prices of commodities are shocked, and the public consumer reaction is monitored. The resulting echoes of the economic shock are interpreted theoretically by computers and the psycho-economic structure of the economy is thus discovered. It is by this process that partial differential and difference matrices are discovered that define the family household and make possible its evaluation as an economic industry (dissipative consumer structure). Then the response of the household to future shocks can be predicted and manipulated, and society becomes a well-regulated animal with its reins under the control of a sophisticated computer-regulated social energy bookkeeping system.

Eventually every individual element of the structure comes under computer control through a knowledge of personal preferences, such knowledge guaranteed by computer association of consumer preferences (universal product code – UPC – zebra-stripe pricing codes on packages) with identified consumers (identified via association with the use of a credit card and later a permanent "tattooed" body number invisible under normal ambient illumination).

The Economic Model

The Harvard Economic Research Project (1948–) was an extension of World War II Operations Research. Its purpose was to discover the science of controlling an

From output

of #

of #

1

2

3

4

...

m

0 v.

γ

0 v.

γ

0 v.

γ

0 v.

γ

0 v.

γ

0 v.

γ

0 v.

γ

0 v.

γ

0 v.

γ

0 v.

γ

0 v.

γ

0 v.

γ

0 v.

γ

0 v.

γ

0 v.

γ

0 v.

γ

0 v.

γ

0 v.

γ

0 v.

γ

0 v.

γ

0 v.

γ

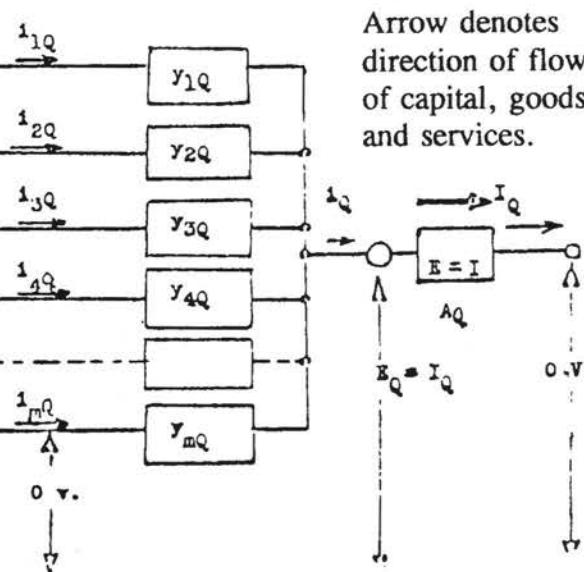

Arrow denotes direction of flow of capital, goods, and services.

economy: at first the American economy, and then the world economy. It was felt that with sufficient mathematical foundation and data, it would be nearly as easy to predict and control the trend of an economy as to predict and control the trajectory of a projectile. Such has proven to be the case. Moreover, the economy has been transformed into a guided missile on target. The immediate aim of the Harvard project was to discover the economic structure, what forces change that structures and interrelationships of investment, production, distribution, and consumption.

To make a short story of it all, it was discovered that an economy obeyed the same laws as electricity and that all of the mathematical theory and practical and computer know-how developed for the electronic field could be directly applied in the study of economics. This discovery was not openly declared, and its more subtle implications were and are kept a closely guarded secret, for example that in an economic model, human life is measured in dollars, and that the electric spark generated when opening a switch connected to an active inductor is mathematically analogous to the initiation of a war. The greatest hurdle which theoretical economists faced was the accurate description of the household as an industry. This is a challenge because consumer purchases are a matter of choice which in turn is influenced by income, price, and other economic factors.

This hurdle was cleared in an indirect and statistically approximate way by an application of shock testing to determine the current characteristics, called current technical coefficients, of a household industry. Finally, because problems in theoretical economics can be translated very easily into problems in theoretical electronics, and the solution translated back again, it follows that only a book of language translation and concept definition needed to be written for economics. The remainder could be gotten from standard works on mathematics and electronics. This makes the publication of books on advanced economics unnecessary, and greatly simplifies project security.

Aggregation

The problem with stabilizing the economic system is that there is too much demand on account of (1) too much greed and (2) too much population. This creates excessive economic inductance which can only be balanced with economic capacitance (true resources or value – e.g., in goods or services). The social welfare program is nothing more than an open-ended credit balance system which creates a false capital industry to give nonproductive people a roof over their heads and food in their stomachs. This can be useful, however, because the recipients become state property in return for the “gut,” a standing army for the elite. For he who pays the piper picks the tune.

The means of surviving the reaction is by changing the system before the reaction can return. By this means, politicians become popular in their own time and the public pays for it later. In fact, the measure of such a politician is the delay time. The same thing is achieved by a government by printing money beyond the limit of the gross national product, an economic process called inflation. This puts a large quantity of money into the hands of the public and maintains a balance against their greed, creates a false self-confidence in them and, for awhile, stays the wolf from the door. They must eventually resort to war to balance the account, because war ultimately is merely the act of destroying the creditor, and the politicians are the publicly hired hit men that justify the act to keep the responsibility and blood off the public conscience.

If the people really cared about their fellow man, they would control their appetites (greed, procreation, etc.) so that they would not have to operate on a credit or welfare social system which steals from the worker to satisfy the bum. Since most of the general public will not exercise restraint, there are only two alternatives to reduce the economic inductance of the system: (1) Let the populace bludgeon each other to death in war, which will only result in a total destruction of the living earth. (2) Take control of the world by the use of economic “silent weapons” in a form of “quiet warfare” and reduce the economic inductance of the world to a safe level by a process of benevolent slavery and genocide. The latter option has been taken as the obviously better option.

At this point it should be crystal clear to the reader why absolute secrecy about the silent weapons is necessary. The general public refuses to improve its own mentality and its faith in its fellow man. It has become a herd of proliferating barbarians, and, so to speak, a blight upon the face of the earth. They do not care enough about economic science to learn why they have not been able to avoid war, despite religious morality, and their religious or self-gratifying refusal to deal with earthly problems renders the solution of the earthly problem unreachable by them.

It is left to those few who are truly willing to think and survive as the fittest to survive, to solve the problem for themselves as the few who really care. Otherwise, exposure of the silent weapon would destroy our only hope of preserving the seed of future true humanity. •...

Footnote

(1) We appreciate any feedback regarding authorship of this document. William Cooper's version of *Silent Weapons* may also be read online at www.9.pair.com/xpoez/money/silent.html, or www.mega.nu:8080/ampp/swfqw.html.

This short excerpt was taken from a pamphlet in our possession since approximately 1993.

WHAT EVIL IS AND WHY IT MATTERS

By John Paul Jones

In one of her songs, Madonna says that she's a material girl, who lives in a material world, who likes material things, etc., so, despite the lack of material in her costumes, Madonna appears to be a materialist. Given her popularity as a pop culture icon and her less than magnificent musical material, I'd also wager that hers is a popular opinion. As such, false it may be, but immaterial it ain't.

Philosophically speaking, a materialist believes that everything which exists within the physical, material world and can be explained by material causes operating in the physical universe, so there is no need to postulate any supernatural, non-physical existents or entities to explain anything.

Thus materialists are often called naturalists, because they deny the existence of anything supernatural, which is to say, non-material. Naturally, as a Christian, I disagree. For not only does the Bible postulate the existence of supernatural or non-physical realities, but those spiritual forces and causes are held to be of paramount significance, as when, for example, the prophet Isaiah, speaking of the Egyptian army, says, "their horses are puny flesh, not mighty spirits," implying that spiritual forces are more powerful than material forces. Or again, when the prophet Jeremiah asks rhetorically, "Should the axe boast that it chops the log?" he is suggesting, I think, that the spirits which vie for the dominion of men's souls are the real forces which move us to do mighty things.

Why, in this case, should we boast of our accomplishments, as though we were the power that moved us? Yet we can, without appealing to scriptures, establish the need to postulate the reality of supernatural (i.e., non-physical) causes, or so I submit, so I believe, and so I will argue here.

According to Occam's Rule, a rule used by scientists, engineers, and philosophers alike, we are justified in postulating the existence of something that's non-observable if and only if postulating its existence is necessary to explain the existence of something which is publicly observable. For instance, in science, black holes and certain sub-atomic particles are inferred to exist even though they cannot be perceived directly via sense-perception, nor indirectly via sophisticated scientific apparatus, because only by postulating their existence can certain known and observable phenomena be explained. Even so, those sub-atomic particles and black holes are inferred to be part and parcel of the material, physical world, so their existence does nothing to establish the existence of anything supernatural. While many scientists resolutely reject the notion of supernatural phenomena, their own discoveries seem to reveal what they refuse to acknowledge.

Proving the Existence of the Supernatural

The discovery of the cause of scurvy is a case in point: For centuries, people died of scurvy before scientists discovered that the disease is caused by a lack of vitamin C in the blood stream. In fact, there is a whole host of ailments which are said to be caused by the chronic *lack* of certain vitamins and minerals. Before science made this discovery, scurvy was presumably identified by its observable symptoms rather than by its cause, and consequently, not knowing the cause, people who could have accessed fruits and vegetables and

obtained sufficient quantities of vitamin C, died needlessly. Whether their deaths were caused by a lack of vitamin C, or a lack of knowledge, or both, we cannot say.

In any case, my question is this: where, exactly, is the vitamin C lacking if not where and when it is needed in the material world? If this lack of vitamin C causes the observable symptoms of scurvy, presumably the lack is real, and if it is real, it exists in some sense, but in what sense, exactly, does this lack exist? Not in the physical, material sense, presumably, for we cannot taste, touch, see, hear, or smell that which is lacking. It's only by measuring and perceiving, via scientific instruments, what is in the blood stream that scientists can then infer, though not perceive via sense perception, what is not in the blood stream.

What is not there cannot be physically perceived, I assume, because it does not exist physically. What is it to say that vitamin C is lacking in the blood stream but to imply that it does not exist in the material world? After all, to say vitamin C is lacking in a person's blood stream is not to say that it does exist but in the wrong place, e.g., on the train to New York, or at the supermarket, or in Madonna's refrigerator. Rather, it is to assert that the vitamin C does not exist where and when it is needed.

Therefore, are we not justified, according to Occam's Rule, in postulating the existence of non-material, non-physical causes; namely, the lack of things needed, and specifically, in the case of scurvy, the lack of vitamin C in the blood stream? If the symptoms of scurvy cannot be otherwise explained except by this lack, then it is necessary to postulate lack of vitamin C as very real and significant, even though it is not an observable, physical thing.

Now if the lack is not real, how can it be said to cause scurvy? If the lack is real, how can it be said to not exist? If the lack does not consist of a material thing or physical substance, how can it be said to be part and parcel of the physical, material world? If, then, the lack is real, non-physical, and known to be the cause of scurvy, how can we avoid inferring that it is a supernatural cause? For to say that something is supernatural

is simply to say that it's real but not physical, not material, and hence, it isn't part and parcel of the natural, physical, material world.

In any case, St. Augustine, among others, acknowledged the reality and significance of a supernatural reality that manifests itself in the material world as suffering and pain, and he named it evil, which he defined as the lack of things needed. For he noted that the things which we call 'evil', such as starvation, poverty, blindness, or ignorance, consist not of anything which exists but of good things which are lacking, e.g.,

blindness is the lack of sight, ignorance is the lack of knowledge, starvation is the lack of food, poverty is the lack of wealth, etc. This absence, or the awareness of it, causes us physical and emotional pain, but pain and suffering are merely the symptoms of evil, not evil itself, according to Augustine. Although all evil causes pain and suffering, not all suffering and pain is evil. It is not evil, in Augustine's view, if the wicked suffer pain or emotional torment for their wickedness. To say otherwise would imply that just punishment is evil. Therefore, it follows, Augustine reasoned,

that evil cannot be defined as pain or suffering.

Even Christian theists have fallen into the error of equating evil as pain. C.S. Lewis, in his book *The Problem of Pain*, seems to equate pain as evil without realizing, I suspect, the logical implications of this false assumption. If indeed evil is pain, then the eternal torment of the wicked would be an evil, and thus, if we accept the doctrine of eternal damnation, of which there is ample scriptural support, Christ would have failed to defeat evil on the cross, since pain, i.e., "evil," would endure forever in hell.

Augustine's Definition of Evil

If evil could be rightly defined as pain and suffering, evil could be destroyed by simply destroying life. In fact, I go so far as to think that the culture of death

St. Augustine acknowledged the reality and significance of a supernatural reality that manifests itself in the material world as suffering and pain, and he named it evil, which he defined as the lack of things needed.

stems from this materialistic and erroneous view of evil as pain and suffering, which leads people to think that death, suicide, or the destruction of life can eliminate evil. This view leads to what might be called the "search and destroy" method of dealing with the problem of evil. According to this methodology, all we need do is find the material cause of evil and destroy it. After, all, since materialists assume all causes are material, they are logically obliged and conceptually predisposed to assume that evil is itself caused by material, physically destructible things or causes.

Consequently, those of a materialist mindset, whether Christian or otherwise, are constantly engaged in campaigns to destroy the evil things or people they think are at the root of the problem. So we have, for example, the "war on drugs," the "war on guns," the "class war" and

The culture of death stems from a materialistic and erroneous view of evil as pain and suffering, which leads people to think that death, suicide, or the destruction of life can eliminate evil.

various genocides—all of which are known to cause more evil than they allegedly uproot, and today, as we witness the spread of eco-fascism in Europe that holds that we can solve the reputed environmental crisis by simply exterminating many millions of people, we also witness the widespread approval of Chinese population control techniques, such as state-sponsored abortion, infanticide, and forced sterilization. Strange fruits and bad apples, all.

Rightly discerning the evil which causes some particular calamity, ailment, or dire predicament is not easy, because the evil does not consist of the presence of anything so much as the lack of something, and things absent but needful are harder to identify than things which are physically perceptible. Add to this the fact that it's much easier to destroy something than to imagine and create that which is needed but lacking.

Thus, we see why materialism is the favored philosophy of dolts. Perhaps the worst consequence of the materialist notion of evil is that it causes people to disbelieve the Biblical account of evil, which identifies our individual and collective sins as the cause of human suffering and pain. An utterly unbelievable claim, insofar as one thinks that physical existents, such as hurricanes, guns, earthquakes, viruses and other material things are the necessary and sufficient causes of human suffering. After all, there is no observable causal relationship between sin and, say, a tornado that wipes out a church congregation.

In truth, it was not the tornado which caused people in the church to be harmed, but rather, the lack of knowledge, foresight, or protection which could have prevented the suffering. If we say instead that the tornado caused the suffering, as though the tornado is evil, we evade the fact that people were ultimately responsible in some way for the pain, else there is no point in calling anything evil, much less inanimate objects. The word 'evil' connotes moral blameworthiness, and its practical utility as a concept is that it helps us to seriously ask the questions that need to be asked: "What could we have done to prevent this suffering? What could our ancestors have done, and how can we avoid making the same mistakes as they did? In short, how do we avoid hell on earth or hereafter?"

Nietzsche, among others, pointed to the fact that in his words, "neediness is needed," which can be construed to mean one of two things: 1) that evil, i.e., the lack of things needed, is needful, and therefore, good; or 2) that imperfection, the lack of things desired, is needful, and therefore, not evil.

The first meaning is logically inconsistent and empirically groundless, so it provides no good reason to reject Saint Augustine's definition of evil. The second meaning is both logically consistent and supported by the evidence. It's also consistent with St. Augustine's definition of evil, and is congruent with the basic premise of economics: that man's wants are infinite and can never be fully satiated. In this case, the lack of things wanted is inevitable and necessary for life as we know it. Imperfection (the lack of things wanted) is "needed" as Nietzsche put it, but evil (the lack of things needed) is unnecessary. •

John Paul Jones may be contacted at PMB 527, Larimer Street, Denver, CO 80202-1610.

Coming in September 2003!
Beings for Intelligent Purpose in
Evolutionary Design (www.BIPED.info)



Tesla Wolf Media

Offers both entertaining and educational media that will definitely have you thinking and second guessing all that is going on around you, with shows like:

Ground Zero with Clyde Lewis

PARANOIAtv featuring:

The Jack Blood Show with Jack Blood

Cancel the Cabal with Stephen Roberts

Outside the Box with Alex Ansary

The Higher Side Chats with Greg Carlwood

Freeman TV with Freeman

The Middle Chamber with Frater X

Cinema Insomnia with Mr. LOBO

Mystery Channel

Anomilies Channel

We are proud to be part of Tesla Wolf Media a streaming multimedia company. Delivering live and on demand shows for your enjoyment.
www.teslawolfmedia.com

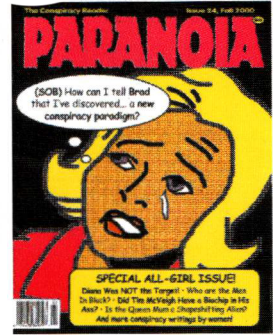
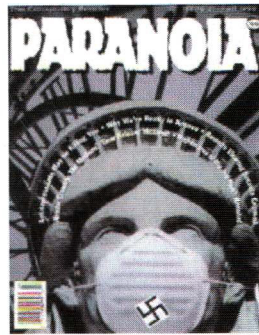

back issues still available!

while supplies last www.paranoiamagazine.com



PARANOIA TV

WATCH AT WWW.TESLAWOLFMEDIA.COM

PARANOIA PUBLISHING

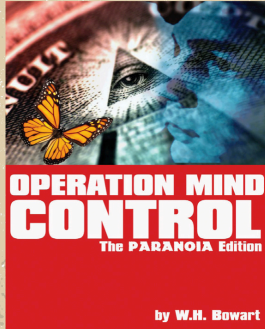

“
Just because
you're paranoid
doesn't mean
they aren't
after you.”

*Joseph Heller
Catch-22*

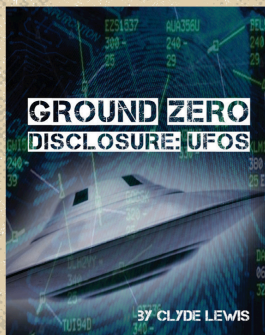
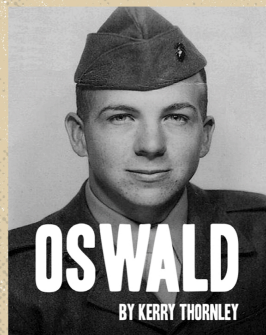

ARE YOU
INTERESTED
IN CONSPIRACIES,
UFOs OR THE
PARANORMAL ?

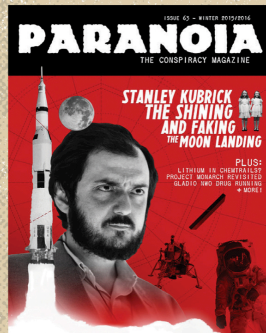

So Are We! Check Us Out at www.paranoiapublishing.com



[HTTP://WWW.PARANOIAMAGAZINE.COM](http://www.paranoiamagazine.com)

SPEAK FREE OR DIE TRYING